

## Do not

**Solder to the power connectors:** it makes it impossible for us to fit them to our test jig if it ever needs repair. Solder is a bad conductor of electricity and using it for power connections can be dangerous.

**Remove the power connectors.** Bolting to the circuit board is less reliable - and the controller will not be repairable as it won't fit our test jigs.

**Let any metal object contact the circuit board.** Even with battery disconnected the circuit can still be live as the main capacitor can store charge for several hours.

**Drill the heatsink or do any grinding, drilling or filing near the motor or controller.** Metal particles in motor or controller can cause failure and will immediately invalidate any guarantees!

**Operate the controller for long if there is an evident fault.** It will survive a shorted motor but only for a short time.

**Disconnect the motor leads when the motor is running.** The resulting arc may destroy the MOSFETs.

**Do any work on the controller with the battery connected!!**

## Other products

4QD manufacture a full range of controllers from our Eagle and IQD series through to our high current 4QD series (up to 300 amps, 36v) as well as a range of extras such as LED voltmeters for 12v and 24v, joystick interfaces and a timer for 'stand-off' operation in golf caddies. We also manufacture controllers for golf caddies, golf buggies, kiddie cars, wheelbarrows, conveyors and other battery motor uses.

## Do

**House the controller properly** so it cannot be contaminated by water, dirt or swarf.

**Discharge the main capacitor** before handling or working on or near the controller.

**Use fully insulated power connectors.**

**Fit a motor Suppression capacitor.** A 10n ceramic capacitor as close to the motor brushes as possible will increase reliability.



"We're in Control"

See us via the Internet:

<http://www.4QD.co.uk>

**4QD Office Stores**

30 Reach Road  
Burwell  
Cambridgeshire, CB5 0AH  
Fax: 01638 744 080

Unit 6A  
Heath Road Industrial Estate  
Burwell  
Cambridgeshire, CB5 0AP  
Email to: [support@4QD.co.uk](mailto:support@4QD.co.uk)



"We're in Control"

Email to: [support@4QD.co.uk](mailto:support@4QD.co.uk)

## Instruction Manual

### Vortex series controllers

#### Vortex-40 and Vortex-75

## Foreword

4QD try to write a manual which is readable. If we succeed and you don't read it there is not a lot more we can do. However if you try to read it and don't understand it (or even don't like our style) - then we have failed so please tell us. Only by means of your criticisms and suggestions that we can improve our publications! To help you, we have marked the more technical sections ¶ so that you may ignore them.

If you have any problems or queries, 4QD pride ourselves on our level of technical advice and if we put as much information into this manual as we could many would find it too long.

If you require more information, 4QD have a very full WWW site which has a large section giving answers to commonly asked technical questions.

Even if you do not have easy Internet access, you will find this well worth reading, so ask a friend who is connected or go to your local Internet Cafe or public library.

4QD's Vortex range of economy 4 quadrant controllers have been engineered to replace the NCC series. As well as improved circuitry, they benefit

from surface mount technology, which offers superior reliability and is better suited to higher volume production.

The Vortices are very suitable for general purpose speed control applications where reversing is required. Amongst other applications our controllers have been successfully used in the following:

- Camera dollies
- Caravan shifters
- Carnival floats
- Conveyors
- Factory stores vehicles
- Floor cleaning machines
- Golf buggies
- Invalid scooters
- Kiddie cars
- Miniature railways, 3", 5" and 7/4 gauge
- Mobile targets
- Mountain rescue vehicles
- Remote controlled vehicles
- Ride on golf buggies
- Winches

In fact wherever battery motor speed control - and good value - is required.

## More information

A manual such as this cannot cover all the points everyone may need to know. For more information visit 4QD's WWW site on <http://www.4qd.co.uk> This contains a lot of information on battery motor control.

If you don't have access, you will surely know someone who does - or visit your local library. You won't regret it!

A full service manual is available from our www site <http://www.4qdtcc.com.service/>



"We're in Control"

See us via the Internet:

<http://www.4QD.co.uk>



**4QD Office Stores**

30 Reach Road  
Burwell  
Cambridgeshire, CB5 0AH  
Fax: 01638 744 080

Unit 6A  
Heath Road Industrial Estate  
Burwell  
Cambridgeshire, CB5 0AP  
Email to: [support@4QD.co.uk](mailto:support@4QD.co.uk)

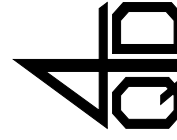

"We're in Control"

Email to: [support@4QD.co.uk](mailto:support@4QD.co.uk)

12th May 2004

# Contents

1 . Introduction . . . . .	p. 2
2 . Handling . . . . .	p. 2
3 . Models . . . . .	p. 3
4 . Safety . . . . .	p. 3
5 . Features . . . . .	p. 4
6 . ¶ Specifications . . . . .	p. 5
7 . Mounting . . . . .	p. 5
8 . Connections . . . . .	p. 6
. . . . . Simple wiring . . . . .	p. 6
. . . . . Push buttons . . . . .	p. 6
. . . . . Power Connections . . . . .	p. 7
. . . . . Battery wiring . . . . .	p. 7
. . . . . Motor wiring . . . . .	p. 8
. . . . . Circuit breaker . . . . .	p. 8
. . . . . Battery condition meter . . . . .	p. 8
9 . Controls . . . . .	p. 8
. . . . . Speed pot . . . . .	p. 9
. . . . . Use as voltage follower . . . . .	p. 9
. . . . . On/Off switch . . . . .	p. 9
. . . . . Reversing . . . . .	p. 9
. . . . . Braking . . . . .	p. 10
10 . Boxed version . . . . .	p. 11
11 . Adjustments . . . . .	p. 11
. . . . . Gain . . . . .	p. 11
. . . . . Ramps . . . . .	p. 11
. . . . . RAT and MST . . . . .	p. 12
12 . Expansion connector . . . . .	p. 12
13 . Heat & Heatsinking . . . . .	p. 13
14 . Choice of motor . . . . .	p. 13
15 . Common faults . . . . .	p. 14
16 . Dos and Don'ts . . . . .	p. 16
. . . . . Other products . . . . .	p. 16
. . . . . More information . . . . .	p. 16
. . . . . Service & Guarantee . . . . .	p. 16

The Vortex series are open-card controllers. A very high proportion of controllers returned for repair have been damaged by mishandling!

Do not let any foreign body contact the board. That includes water, dirt, screwdrivers, nuts and bolts.

Use only fully-insulated power connectors.

The controller can be damaged by foreign body contact **if the main capacitor is still charged.**

## 1: Introduction

4QD's Vortex range are high frequency chopper drivers giving control of motor speed both in drive mode and in braking mode. They use MOSFET's in state-of-the-art high frequency circuitry to give best possible performance and battery economy. The controllers incorporate many advanced features such as regenerative braking, independent, linear, adjustable acceleration and deceleration ramps, reverse speed reduction, dual ramp reversing, fault protection, thermal protection and electromagnetic brake driver.

Many of these features can be disabled if so required. Some features are optional on the smaller controllers. The Vortex features a 'double ended' layout with the power components in the centre. This is physically slightly less convenient than, for instance, our Pro-120 controller but does result in a more economical controller.

The simplest possible configuration is shown on page 6. The Vortex series have many other features so there is a lot of extra information in this manual. Please don't be put off but read the manual quickly through before you start. This should introduce you to what you can do with our controllers and clarify what we are trying to say.

Our drives are protected: provided you don't actually connect them wrongly or short them out, they will survive almost any type of motor - we regularly use a 12v starter motor as a test load, stalling it with a monkey wrench. The drives survive this but will get hot and therefore may eventually fail.

## 2: Handling

Before handling the controller or unplugging the power or motor connections, disconnect the battery, then leave the ignition turned on *for at least one minute before* handling the controller, to discharge the main capacitor.

Otherwise, short out the battery inputs to the controller, to discharge the capacitor to make the controller safe to handle.

See also back page for dos and don'ts

part of the circuit board the controller may well fail. The capacitor can only heat while the controller is actually working properly so capacitor failure is always simply down to overloading the controller in one way or another.

### Overheating

If any electrical item is worked hard it can get hot. If it is overworked for too long it will simply get hotter and hotter until something fails. Depending on the nature of the installation and overloading, solder joints can melt, the main capacitor can vent and the MOSFET's may then fail. Fortunately such severe overheating is not common.

Sustained overheating causes the varnish around the heatsink and capacitors to discolor. This is not in itself harmful but can indicate problems.

### No reverse.

- If the controller won't reverse there are two distinct possibilities:
- 1 The motor still goes forward when reverse is selected.
  - 2 The motor is dead when reverse is selected

The first fault is likely to be a wiring fault: the reverse signal is not getting to the controller. Measure the voltage on the black wire to pin C (measure with respect to battery -ve). If this is low (below about 6v) the controller will go forward. When high (above about 6v) the controller will reverse. The reversing switch connects this pin to battery positive to apply a

voltage to reverse it.

The second fault is usually in the controller: if a relay clicks in the 'dud' direction, try cleaning the relay contact. One relay operates for forward, one for reverse. Current flows from battery positive, through the normally closed contact of the relay which hasn't moved, then through the motor and so through the now closed contact of the relay which has operated. Usually the normally closed contacts tend to get dirty easier (lower contact pressure). Clean with fine emery paper.

## Service

We can repair damaged controllers. But please be sure that the controller is faulty before returning it as we may make a charge for handling controllers which are not faulty or which only have the fuse track blown.

There will be a charge made for repairing controllers with blown fuse track.

There is an additional handling charge made if controllers are returned in boxes. The box itself never requires and servicing!

Otherwise charges made will depend on the age and condition of the controller and on the fault as we tend to be fairly lenient in interpreting the guarantee!

Make sure you include your name, address and details of the fault with the returned controller.

### Fuses.

The main 'fuse' is a zig-zag section of track shown to the right. It is situated on the underside of the board, just by the battery + connection.

If it fuses, solder a fine piece of wire over it - a single strand from 7/0.2 cable is fine. Special pads have been placed for this purpose.

There are also similar fuse tracks to pins A & F of the 6 pin input connector.

In practise fuse tracks are very fickle: it would be possible to design a board with 5 different fuses each one of which could blow singly and separately under different overload characteristics: we cannot guarantee therefore that the correct piece of track will always blow! So if in doubt, fit a separate fuse.

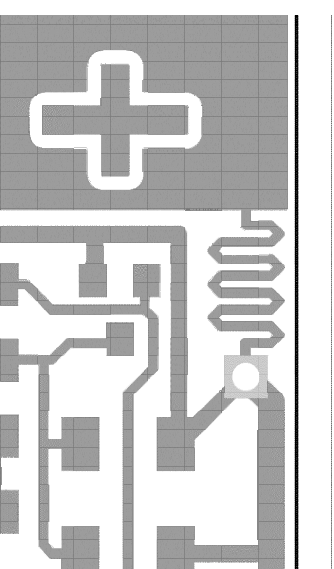

wrong voltage, will normally still go approximately at its designed speed. This is because its field current reduces (or increases) in proportion and the motor speed has to increase (or decrease) proportionally to compensate.

The nameplate current quoted for motors is normally

## 15: Common faults

Faults are not 'common': as soon as 4QD find a fault which occurs often enough to recognise it as a problem, we try to alter the design to eliminate it. This policy makes it difficult to give you sensible fault finding tips - but it does improve our product!

The vast majority of controllers returned have no fault, or simply a fuse track has been blown by a wiring fault (see back page for fuse information). Of the rest, most failures are due to misuse, albeit often through misunderstanding.

We cannot do a lot about external wiring faults except to protect the controller as much as possible. However if a bad fault occurs in the controls (connected to the 6 pin input connector) the controller has been designed to protect itself and minimise damage. So there are weak points (fuse tracks) in the controller intended to limit the damage - see opposite.

Sometimes wiring faults (e.g. a short between +24v and the pot) will feed current back into the controller and blow the 9v1 zener diode. This usually fails safe (short circuit) so that there is no voltage feed to the pot. This is probably a return to base repair - unless you feel confident with a soldering iron, in which case ask us for help.

The zener can also be blown sometimes by mishandling, e.g. disconnecting the controller than putting it down on a metal object: the main capacitor stores charge for a considerable time.

Some problems are caused by the wrong wire in the IDC connectors.

MOSFETs do fail occasionally: they are doing an enormous amount of work and sometimes one simply gives up: commonly the drive MOSFETs cause their drive resistors to burn up - a sure sign the MOSFET has failed.

a continuous rating: most motors will safely take an overload of about 400% for short periods. The current the motor actually requires is determined by the mechanical loading, not by the controller or the motor. If the motor is too small, it will overheat and if the controller is too small, then it will overheat. For more information on motors, contact 4QD.

## 15: Common faults

An understanding of the internal powering arrangements may help you find problems (both in the controller and in your wiring).

Connecting the ignition to battery positive turns on a current source (about 30mA) which powers all the internal circuitry, using a 9v1 zener diode as a regulator. This system is very reliable as it tends to fail safe: zeners when overloaded usually fail short

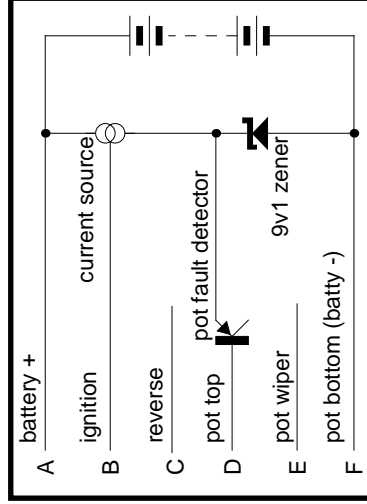

circuit, which removes all internal power.

The 9v1 line is fed to the top of the pot via a transistor (which detects open circuit pot wiring), so when the internal supply is powered up you can measure about 8.5v across the pot. Operating the pot will, then, change the blue wire to pin E from 0v to 8.5v, depending on the pot setting.

### Main capacitor:

Be aware that certain uses of the controller can cause this to heat, particularly if the battery leads are long. The main capacitor may get warm, but should not be allowed to remain hot to touch for too long. Heating will shorten the life of this capacitor and, if excessive, can cause it to vent. When it vents, the liquid electrolyte inside boils and vents. Although the capacitor failing does not do any direct damage (the controller simply loses power) the venting capacitor can expel hot electrolyte: if this gets on to the wrong

## 3: Models

2 models are available, for different current ratings and with different options. Each is available as 12v or 24v, but the 24v can be supplied with resistors in the relays for 36v operation. Also available are -48v versions.

NCC-35-12, -24, -36 & -48 35 Amps 55A max typical  
NCC-70-12, -24, -36 & -48 70 Amps 110A max typical

Slave versions of all options possible or two standard units can be interconnected in tandem

The voltage is marked on the relays. Make sure these are correct as 24v relays will not operate from 12v and 12v relays will soon burn out their coils if used on 24v.

36 and 48v versions use the 24v relays but with a resistor in series with the relay coils and other components changed as appropriate.

A boxed option is also available.

## 4: Safety

It is normal practise, on passenger carrying vehicles, to include some means of disconnecting the battery or motor in an emergency. This could be a "kill switch", or perhaps a removable link in the battery wire. This is to guard against a failure in the controller or wiring which, although very unlikely, could cause the motor to run at an uncontrollable top speed.

Even without such additional safety features, the Vortex range controllers are designed so that failure, and particularly dangerous failure is very unlikely.

Experience also shows that, in the improbable event of a power device failing, the device normally acts as its own fuse, removing drive from the motors. Furthermore, notwithstanding a very unusual fault, the motor can be stopped quickly by turning off the ignition, or turning the speed down to 0. Either action operates the relays to give full emergency braking.

Most dangerous faults have been due to water splashes on the board - which is outside of our control. No manufacturer, however careful, can always guarantee what will happen in the event of a failure.

It is important for the last word here be that the constructor should fit a means of quickly disconnecting the battery in the event of abnormal control system operation.

All passenger carrying vehicles should, in any case, be fitted with a mechanical braking system to complement regenerative braking.

### Reversing

On the Vortex controller series, reversing is normally 'dual ramp'. This means that, when the reversing switch is operated at speed, the controller slows down under control of the deceleration ramp, automatically reverses and accelerates again under control of the acceleration ramp. If the ramp controls are set for quick response this process can be quite violent.

Also, reversing is done by monitoring the demand speed, after the ramp circuit and not by measuring the motor voltage so that, if the vehicle is reversed when going down a hill, the motor will still be rotating and the vehicle will be travelling when reversing occurs. Reversing can therefore be accomplished on any hill but it will be more or less violent if the gradient is steep depending on the setting of the ramp controls. The user is best advised therefore not to reverse on steep hills!

Dual Ramp reversing can be deactivated, when the reversing becomes pre-select.

## 5: Features

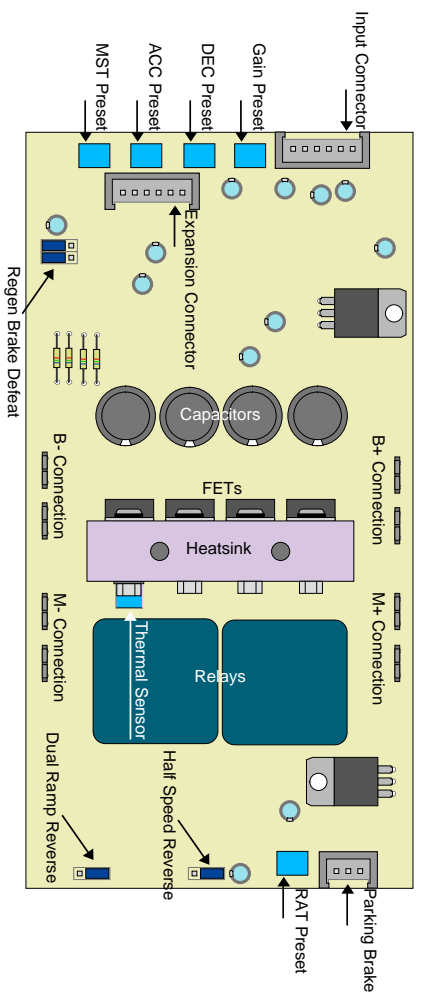

The diagram above shows the Vortex-75 which has four MOSFETs and capacitors. The Vortex-40 has two only. Otherwise, the Vortex-40 is largely the same as the Vortex-75.

Speed pot and reversing switch input is via a 6 pin connector, supplied.

Power & Motor connections are by 6.3mm blade connectors on top of the board. Spare power connections are provided and can be used for control wires or for extra motor wires as you wish.

9.5mm blade connectors are available as an option. Also available is an expansion connector option, see page 12.

## 13: Heat & Heatsinking

The rated current output of the controllers is with the heatsink hot. When cold they will give considerably more current. Thus the 40 amp version will in fact give about 55 amps when cold. This is OK because the MOSFETs used are rated at 60 amps continuous with a case temperature of 25°C. As the MOSFETs warm up their allowable current reduces so that at a case temperature of 100°C they can (only!) handle 42 amps each continuously. The current limiting used in 4QD's controllers senses the MOSFET temperature and automatically adjusts as the MOSFET's heat up. However, running the controllers at full current will cause speedy heating so the allowable continuous current will depend on the external heatsinking.

## 14: Choice of motor

All speed controllers should only be used with good quality motors. Old, dirty motors can have damaged, worn brushgear and this causes arcing. On occasion arcs at the brushes can cause seemingly random controller failure. Fortunately this effect is quite rare, but it's best to be careful.

Ideally the motor should include an internal suppression capacitor, a ceramic type of 10n value is suitable. If the motor does not include this you are advised to fit one across the brushes as close as possible to the motor body. The controller will work without this capacitor, but it can lengthen the life of the system.

A word of warning: many car type motors have the chassis connected to one terminal. Take great care with these as you could easily short the controller out - which would be fatal. It is best to avoid these motors. Otherwise either make sure the motor is mounted on insulation (including the drive shaft), or make certain that no other point of the control system can be earthed to chassis. If in doubt contact 4QD.

Most modern d.c. motors use permanent magnets. These are the best for battery operation. However, other types can be used: at 4QD we regularly use a 12v car starter motor for testing (even with our 24v 150 amp drives) since these are a far worse load than is ever likely to be met. Into such a motor (stalled) the controllers simply deliver their maximum current

Steel is not a good heatsink material: heat does not flow easily in steel. Aluminium or copper is far better. If you have a steel plate, sandwich an aluminium sheet between the steel and the Vortex to spread the heat. For really arduous use we suggest heatsink compound between the Vortex's heatsink and your own: this helps heat flow across the join. Make sure both surfaces are flat and free of grit.

The Vortex-75 incorporates a thermal sensor (optional on other models) which cuts back the output current if the controller gets too hot. The Vortex-75 cuts back to about 20 amps, when the MOSFETs will dissipate about 20 watts. This is still enough to overheat the controller if no external heatsink is used, so don't rely on it!

and get hot. It is virtually impossible to damage the controllers by an unsuitable motor (the controller will simply get hot quickly), so don't be afraid to experiment.

There is no reason why you cannot use a 24v motor from 12 volts - it will only go at half its design speed. Also, if you use a 12 volt motor from 24v, it will go at twice its rated speed. Since the Vortex is current limited you won't overload the 12v motor, provided it can handle the available (limited) current.

**Shunt wound motors** can be used if the field winding can be separated. Connect the field winding permanently across the supply and control the armature winding: the shunt wound motor then behaves like a permanent magnet motor.

**Series wound motors** may also be used but they cannot give dynamic braking and are very inefficient at low speeds so are not ideal. To use them with the Vortex series a modification must be made so the field can be correctly connected into the relay circuitry: contact 4QD.

You can reverse a field-energised motor by simply swapping over the field windings. You should not do this when the motor is rotating as armature currents will then be very high. The field will draw much less current than the armature so a much smaller switch will suffice. A field energised motor, used on the

## RAT and MST

Two other presets exist: we advise against altering these.

Normal setting is centre scale.

**RAT**. As the throttle is moved from zero, at a low setting one or other direction relay engages

(depending on the selected direction). This is the RAT (Relay Activate Threshold). At the same point, the parking brake is released.

**MST**. As the throttle is further advanced then, normally just above the RAT, the controller starts to modulate: i.e. voltage is fed to the motor. This is the MST (Modulation Start Threshold).

If you wish to adjust these parameters and are not completely and utterly satisfied that you know what you are doing, please contact 4QD.

Because of stiction in the motors, they need a small voltage before they start to rotate: this will occur at a lightly higher throttle setting.

## 12: Expansion connector

This 6 way connector may be fitted as an option. This expansion connector has two main uses:

- 1 't' Version. To fit a board to work with a tachogenerator in a closed loop speed control system: this gives far better speed control range and improves performance (especially torque) at slow speeds.
- 2 'D' version. For ganging two Vortex controllers together, either for a two motor vehicle or for occasional use, as when double heading a loco.

### Double heading - D version

When two standard controllers are connected together via the expansion connectors, one is used as the master and the second becomes the slave. The master is connected normally and controls one motor and its parking brake (if fitted).

The slave controller *needs* only battery connections and connections to the second motor. If other controls are fitted to the slave, then a 'voting' system operates: If either ignition is on, both controllers operate. If reverse is selected on one, both will reverse.

If speed is non-zero on both controllers, then the fastest selected speed will control both.

So to avoid confusion, simply plug **nothing** into the 6 way input connector on the slave!

The slave is connected to the master Vortex via a 6

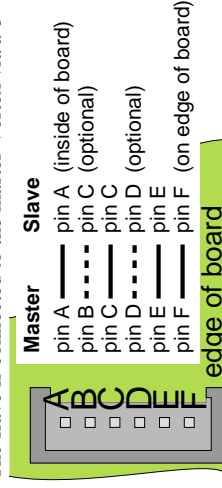

## 6: Specifications

Supply voltage	12v, 24v, 36v or 48v	different models.
Supply current	25mA	at zero speed
Motor speed	0 to 100% full speed	adjustable
	0 to 50%/100% full speed	selectable
Output current	35A hot	55A cold
(typical)	70A hot	110A cold
Overheat temperature	95°	on heatsink
Overheat current	20 amps	typical
Switching frequency	20kHz	approximately
Size	153mm x 78mm x 45mm	
Weight	260g	
Input	2k to 20k pot.	
Pot fault detect	greater than 25K	adjustable
Input voltage	3v to 20v for full speed	adjustable
Acceleration time	100mSec to 5 Sec	adjustable
Deceleration time	100mSec to 5 Sec	adjustable
Relay Activate Threshold (RAT)	0mV to 100mV max	Approx range
Modulation Start Threshold (MST)	0mV to 650mV max	Approx range

## 7: Mounting

The Vortex series are designed for mounting via the heatsink as in the diagram below. In most applications, full current is only drawn for short periods so little heating will be experienced.

However, the Vortex's heatsink is a thick block of aluminium which won't cool down quickly to the air. In more demanding applications, good heatsinking is important, such as a suitable metal plate which will usually be the vehicle's chassis. If heatsinking is inadequate, the controller will give reduced performance, and if allowed to overheat for too long, may be damaged. The heatsink is completely electrically insulated.

Mounting holes in the heatsink are tapped M4. Do not drill these out larger. It is unnecessary and you

will contaminate the board with swarf, invalidating any guarantees.

For more information on heatsinking, see page 13 You can also mount the controller in a diecast aluminium box, e.g. Eddystone 26827PS.

We recommend mounting only by the heatsink. However if you want to use the corner mounting holes as well, you must use insulating mountings.

Whatever you do, make sure the controller can't get wet and, if it does, don't connect the battery until you have dried the controller thoroughly. The water won't cause damage unless the unit is connected to the battery, when electrolytic corrosion will occur.

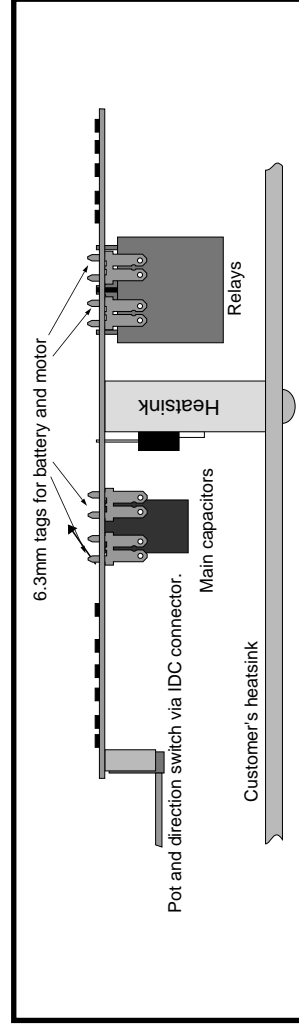



## 8: Connections.

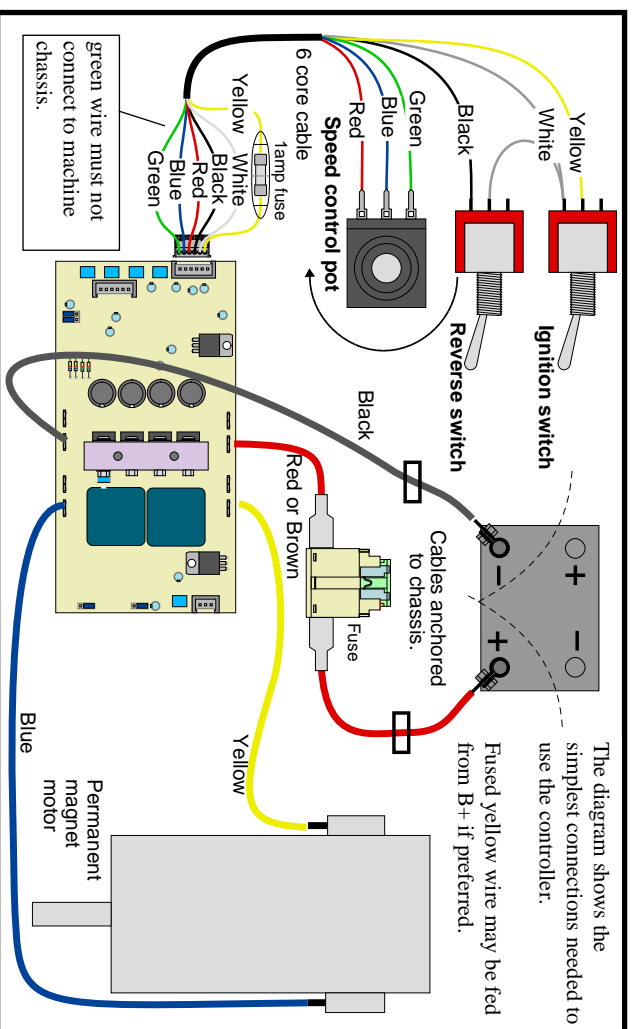

The diagram shows the simplest connections needed to use the controller.

Fused yellow wire may be fed from B+ if preferred.

### Battery Fuse

*Note also the fuse in the battery line:* this is really only to give a useful measure of protection against a reversed battery. The boxed unit has a 40 amp fuse fitted but the controller may easily draw more than this depending in the application. A larger fuse can be fitted, but will give less protection in the event of the battery being reversed. Use the smallest value fuse which does not cause nuisance blowing: if the controller is giving more current than it can readily handle it will simply get hot.

See also page 8.

A relay may be used as an alternative. See 'Polarity' on facing page.

### Push buttons

Instead of two switches (ignition and forward / reverse) you may use two instantaneous push-buttons. Wiring is shown left: note the extra diode

Without this, reverse will not work. The diode's Cathode (the end with the band) should be connected to White.

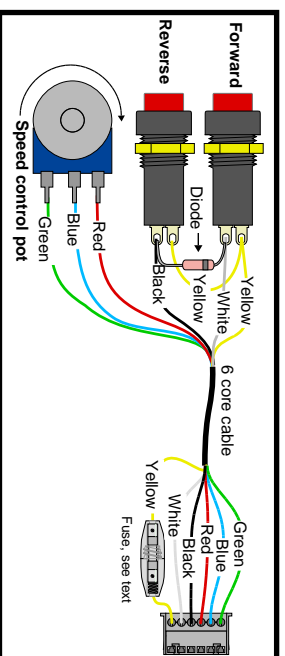

## Boxed Controller

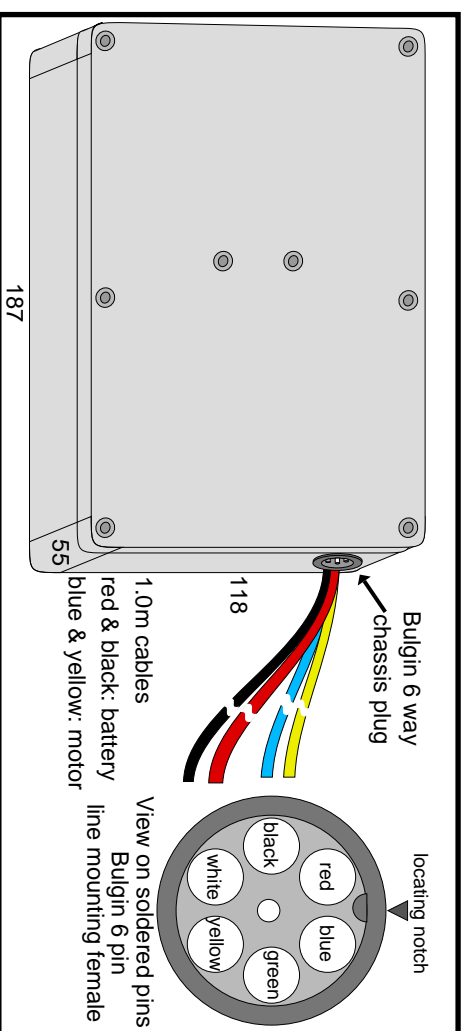

### Adjustments

#### Gain

This is marked 'Gain' on the diagram 'Features'. Set this so that, at maximum required pot range, the controller just reaches full speed: this is easiest to do with the motor unloaded. Set the speed pot to your required maximum point (e.g. full up) then, listening to the motor, adjust the preset. It is usually quite easy to tell when the motor stops accelerating.

Maximum setting of the gain preset will give full output for about 3v input.

#### Ramps

The Vortex series controllers incorporate linear ramps to control the maximum acceleration and deceleration rates. These are user adjustable and, to get best performance from your machine, you should adjust them to best suit your application.

#### Acceleration ramp

This is labelled as 'ACC' on the circuit board: it is present to make the vehicle accelerate smoothly when the speed pot is increased suddenly, so as to avoid sudden surges and shocks to mechanical components. As supplied it is normally at half setting so that the motor takes about 2 seconds to accelerate. Adjust it as you require to give smooth acceleration.

Clockwise increases acceleration (reduces time to full speed), anticlockwise decreases acceleration (increases time to full speed). If the acceleration is set

### Simple wiring

On the 6 way multicore control wire, yellow is directly connected to battery +ve. White and black may also be battery +ve (depending on the control switches). Green is battery -ve and blue and red are the control pot. A short circuit in the wiring between these two groups will cause problems!

**Boxed version:** Wire colours are as shown in the diagram above.

*Note the 1A fuse in the yellow wire.* If this is omitted, a mistake in the wiring can blow fuse tracks on the controller. Controllers returned for repair with the fuse tracks blown will be subject to a handling charge, so if you are happy to repair these fuse tracks yourself, you do not need this fuse! See page 15.

too high (anticlockwise) the acceleration may be limited by the current limit, which does no harm but means that acceleration is not being controlled properly, so will be dependent on motor load.

#### Deceleration ramp

This is shown as 'DEC' on the circuit board: it is present to make the vehicle decelerate smoothly when the speed pot is reduced suddenly. As supplied it is normally at half setting (about 3 seconds). Adjust it as you require to give smooth deceleration. You will usually find you require a lower setting (more anticlockwise) for DEC than for ACC. If the Decel time is set too low (anticlockwise) then the relays will drop out (and short out the motor) before regenerative braking has finished, giving a jerk before the vehicle stops completely. This will also shorten the life of the relays.

#### Warning

On the -RW version, be careful not to set the ramps too fast: if reversing is too fast the relays can arc, causing them to stick and also shortening their life. This is fully explained on our [www. site: http://www.4qd.co.uk/ser/ncramp.html](http://www.4qd.co.uk/ser/ncramp.html)

## Dual Ramp Reversing

'Dual ramp' reversing can be disengaged by removing the header marked Dual Ramp on the diagram, page 4. Reversing then becomes 'pre-select' so that, if the reverse switch is operated at speed, nothing will happen until the demand speed is reduced to zero.

Reversing will now occur when the demand speed is turned up again. In this mode a push switch can be

used for reversing: push the switch as you move the speed control from zero to engage reverse and release it when the vehicle is moving. Then, when the speed control is again reduced to zero, the controller will drop back into forward.

Pre-Select reversing *must* be used for series-wound motors or if regen braking is disabled.

## Braking

### Regenerative Braking

Regenerative motor braking is integral to the Vortex controllers. When the demand speed is reduced below the actual motor speed, the controller starts braking, returning as much of the braking energy as possible back into the battery. The speed at which the braking acts is adjusted by means of the deceleration adjustment.

Regenerative braking does not work well at very slow speeds, simply because it relies on the motor turning to provide braking energy. If the motor is only turning slowly then it cannot give a lot of braking, so a vehicle will creep if parked on a hill. To stop this you can get motors fitted with an electromagnetically operated parking brake. When power is applied to this, the brake is removed and when power is removed the brake is applied by a spring.

There are few applications where regenerative braking is deleterious and it should normally be left engaged.

The ability to disable regen braking can be included as an optional extra if requested at point of purchase.

*When regen braking is disengaged:*

- 1: the controller **must** be also switched to pre-select reversing (see above).
- 2: Choose the longest deceleration ramp setting, as the motor will brake only under friction.

Failure to do this will cause jerky performance and may burn out the relays.

## Power Connections

### Battery wiring

Battery connections to the controller are shown in the diagram opposite. Use only good quality battery connectors: the controller feeds current back into the battery during braking and if a battery connector falls off when braking this regenerated current can pump up the voltage on the dud battery connection. Although the controller is protected against damage from this, it is not advised. The same will happen if a fuse or circuit breaker opens during braking.

Note that, if the battery is disconnected for a minute or more, when the battery is re-connected, it is normal for there to be a noticeable spark as the main capacitors charge.

### Polarity

Take great care:

**THE CONTROLLER IS NOT POLARITY PROTECTED: BATTERY REVERSAL WILL INSTANTLY DESTROY THE CONTROLLER!**

This will not be covered by the guarantee! To avoid this possibility we suggest you anchor the battery wires to the chassis at a suitable distance such that, if the battery is turned round, the battery clips won't reach the terminals which are now in the wrong position (shown by the empty circles). A suitable arrangement is shown in the diagram opposite.

If you wish to better protect against reversed battery than will a fuse, this can be done by wiring a suitable relay (one normally open contact) in the positive battery lead. One end of the coil connects to battery -ve and the other to pin B of the input connector which is also connected to the ignition switch. A resistor must be connected across the contacts as shown. When the ignition is off, there is no voltage

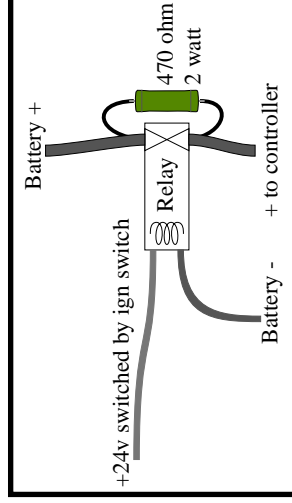

Vortex series instructions

on the relay coil and the relay contacts are open. The Vortex's main capacitor charges through the 470 ohm resistor.

If the battery is reversed the Vortex's MOSFETs short out the capacitor, so no voltage is present and the 470 ohm resistor limits the current to a safe value. When the ignition switch is closed the relay coil is connected across the capacitor: if there is voltage (battery correct) the relay operates and applies full power.

4QD can supply a suitable relay (**RLY-724**) for 24v only but a 12v version is common in car electrics.

**Wire size.** Use heavy duty wire for the battery and make them as short as possible. This also applies to the battery linking wire on 24v systems. 4mm (12awg) wire is 'officially' rated to handle 41 amps continuously. At 100 amps it gets too hot to touch within about 60 seconds. We therefore suggest you use 6.0mm<sup>2</sup> (10awg) wire for the 75 amp version and 4.0mm<sup>2</sup> for 50 and 35 amp versions. Thicker wire will cause no problems, so use the thickest you have.

Use of wire that is too long (and/or too thin) will cause loss of power, but more importantly the decoupling capacitor (see 'features' diagram above) will heat up. Heat will shorten the operating life of capacitors.

### Crimp Contacts

It is **VERY IMPORTANT** that you use fully insulated crimps: the power connections are close to the board. Uninsulated crimps may short out and destroy the controller. Best of all use 'F type' crimps with vinyl covers shown in the drawing.

4QD can supply these pre-crimped - they require a special crimp tool.

Also be aware that the main capacitor can store charge for a long time, up to 24hours even, so the potential for damage is there long after the battery has been connected.

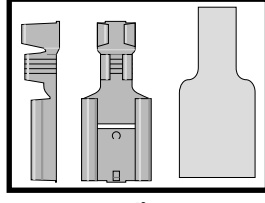

used for reversing: push the switch as you move the speed control from zero to engage reverse and release it when the vehicle is moving. Then, when the speed control is again reduced to zero, the controller will drop back into forward.

Pre-Select reversing *must* be used for series-wound motors or if regen braking is disabled.

## Braking

To deactivate regen braking:

- 1: DISCONNECT CONTROLLER FROM THE BATTERIES

- 2: Remove the two links labelled RBD.

The following diagram shows the permitted configurations of the RBD jumpers. Any other configuration will damage the controller.

(need a diagram of good)

### Parking Brake

Some motors are fitted with a separate solenoid released parking brake.

The Vortex controller has a circuit to drive such a parking brake brake: power is applied to the solenoid as demand speed is increased above zero and when the demand speed returns to zero, power is removed.

Parking brake is via the 3 pin connector, shown on the diagram 'Features'. Wiring is as the diagram below.

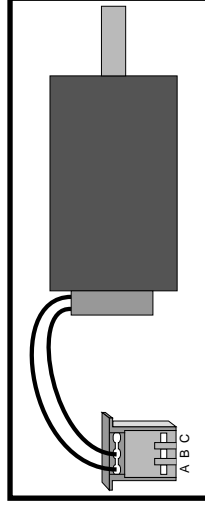

This feature is standard on Vortex-75 but is an optional extra on the Vortex-40.

## Motor wiring

This is not so critical as battery wiring: 100 long and/or too thin wire will cause a loss of maximum current, will get hot and will waste battery power but will not damage the controller. However, wire which is too thick will do no harm either so we recommend the same wire for the motor as for the battery.

## Circuit breaker, fuse, isolator.

A circuit breaker or fuse may be fitted if required. The main advantage is that it will enable the battery or motor to be disconnected in the event of an emergency or for security and it may give a measure of protection should the battery be reversed.

Alternatively, you could fit a breaker in the battery lead: take care not to increase the wiring length too much. Also, certain types of breaker can have the same effect as increased battery lead length.

A breaker in the motor may also be useful: it will enable you to quickly disconnect the motor in an emergency. If correctly rated, this can also protect the motor against overheating due to mechanical faults. Also with the motor disconnected, free-wheeling becomes possible.

It is also possible to get a battery isolator switch. These are normally fitted to lorries, buses and boats to isolate the battery in an emergency.

## Battery condition meter.

Pins A and F (yellow and green on the diagram) are directly connected to the battery so that you may use them to connect a battery condition meter.

The drawing shows 4QD's LED battery indicators.

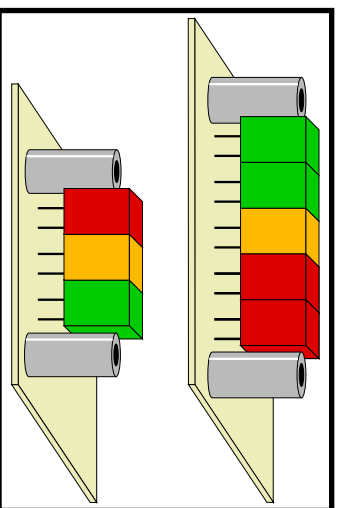

## 9: Controls

### 6 way connector.

The mating connector supplied is suitable **only** for the correct size of wire.

Acceptable wire sizes are:

- ... 7 stranded 0.22-0.25mm<sup>2</sup>
- ... Equivalent 24 AWG (7/32 AWG)

It is an Insulation Displacement Connector (IDC) which 4QD have chosen because it is so very easy to use and very dependable. - but only with the correct wire!

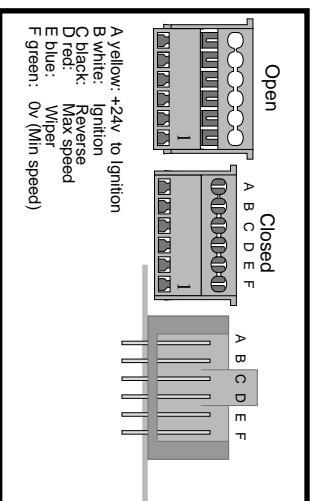

Do not strip the insulation from the wires, simply push them into the top part of the open connector and squeeze it closed in a vice or with suitable parallel action pliers. As you do this the tines of the contacts bite through the insulation to make contact with the conductors.

Wire which is too thin will not make contact. Wire which is too thick will damage the tines.

Do not use single strand (telephone) wire: it will make unreliable contact and easily breaks.

You can re-open a closed connector by gently moving the tabs at the sides of the top cover outwards to disengage the latches while lifting the cover slightly, one side at a time.

## Speed pot.

We suggest a 10K linear pot, although other values from 4K7 to 20K, linear or log, can be used.

The gain adjustment on the controller alters the amount of rotation required before full speed is reached: this enables a simple lever operated control by means of a lever arm screwed onto a standard rotary pot.

The simplest speed control is an ordinary rotary pot: this won't give any 'dead man' control as the pot won't return to zero when it is released. 4QD can supply a spring return to zero hand control.

Alternatively 4QD can supply a plunger operated pot (linear position sensor), suitable for incorporating into a foot pedal.

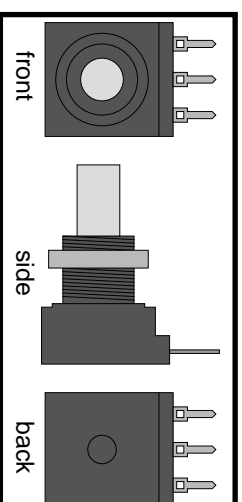

The drawing shows the pot supplied by 4QD

With this pot you should only solder to the tips of the tags: the holes shown are not for soldering but as heat barriers to stop heat travelling up the tag and melting the plastic body.

## Use as voltage follower

Instead of a pot, the input may be fed from a variable voltage. 0v (common) to pin F, signal input (+ve) to pin E. A resistor (10K) should be connected from pin D to pin F to over-ride the internal pot fault detector circuit.

Zero speed will be for zero voltage input and full speed voltage may be adjusted (by the pre-set) to be from 3v to above 20v.

Ignition and reverse inputs are both high impedance (voltage controlled). High activates. Thresholds are around 5v for both.

## On/Off switch

Circuitry in the controller switches it off (zero current consumption) unless there is a voltage on pin B or pin C.

The wiring is shown on page 6.

Beware of changing any switch when the motor is running: the motor will brake to a halt more or less quickly, depending on the deceleration ramp setting.

If the switch changed is the reverse, it will then accelerate up to speed in the other direction. This process is quite safe (for the controller).

With the ignition off, or even with the battery disconnected, the relays short out the motor so free-wheeling is not possible. To free-wheel properly the motor should be disconnected.

## Reversing

### Reversing switch

Reversing switch connections are shown in the diagram above. Reversing is 'dual ramp' which means that, if the vehicle is reversed at speed, it automatically slows down under control of the deceleration ramp then reverses and speeds up under control of the acceleration ramp.

Whenever the vehicle is in reverse, a speed reduction circuit operates, so that (if the gain adjustment has been set up sensibly) full reverse speed is half of full forward speed.

### Reverse Speed reduction

If reverse speed reduction is **not** required it can be disabled by moving the header marked 'S' on the board and in the 'features' diagram. This is a pinstrip with a shorting link which simply unplugs. As shown (bottom pin free) reverse is the same as full speed. As supplied (top pin free) reverse is at half speed.

### Reverse threshold

If you are reversing the controller from, for instance, a microcontroller, the threshold is around 5v. A voltage above this selects reverse, below the threshold selects forward.