

## Environment-Proof 120A Brushless DC Motor Controller with Field Oriented Control USB and CAN



Roboteq's KBL1xxx is a rugged, feature-packed, high-current single channel controller for brushless DC motors. Built in a water and dirt resistant enclosure, the controller can operate in one of several modes in order to sense the rotor position and sequence power on the motor's 3 windings in order to generate smooth continuous rotation. The controller also uses the Hall sensor and/or Encoder information to compute speed and measure traveled distance. The motor's may be operated in open or closed loop speed mode, position mode or in torque mode.

The KBL1xxx features several Analog, Pulse and Digital I/Os which can be remapped as command or feedback inputs, limit switches, or many other functions. The KBL1xxx accepts commands received from an RC radio, Analog Joystick, wireless modem, or microcomputer. Using CAN bus, up to 127 controllers can be networked at up to 1Mbit/s on a single twisted pair.

The controller's operation can be extensively automated and customized using Basic Language scripts. The controller can be configured, monitored and tuned in real-time using Roboteq's free PC utility. The controller can also be reprogrammed in the field with the latest features by downloading new operating software from Roboteq.

### Applications

- Small Electric Vehicles, Electric Bikes
- Electric Boats
- Terrestrial and Underwater Robotic Vehicles
- Automatic Guided Vehicles
- Police and Military Robots
- Material Lifting Systems
- Animatronics
- Industrial Controls
- Hydraulic Pumps control

### Key Features

- RS232, RS485, 0-5V Analog, or Pulse (RC radio) command modes
- Auto switch between RS232, Analog, or Pulse based on user-defined priority
- CAN bus interface at up to 1Mbit/s
- Built-in 3-phase high-power drivers for one brushless DC motor at up to 120A RMS (170A DC equivalent)
- Trapezoidal commutation based on Hall Sensor position information
- Trapezoidal Sensorless
- Smooth and quiet three Phase sinusoidal mode
- Support for absolute angle encoders
  - Sin/Cos analog
  - SSI digital
  - Resolver
- Field Oriented Control in Sinusoidal modes
- Full forward and reverse motor control. Four quadrant operation. Supports regeneration
- Safe Torque Off - STO (Certification Pending)
- Operates from a single power source
- Programmable current limit up to 120A RMS for protecting controller, motor, wiring and battery.
- Separate waterproof M12-type connector for Hall or SSI rotor sensor
- Accurate speed and Odometry measurement using Hall Sensor or encoder data
- Quadrature encoder input with 32-bit counter
- Up to six Analog Inputs for use as command and/or feedback
- Up to six Pulse Length, Duty Cycle or Frequency Inputs for use as command and/or feedback
- Up to six Digital Inputs for use as Limit Emergency stop or user inputs

- Two general purpose 40V, 1.5A output for brake release or accessories
- Custom scripting in Basic language. Execution speed 50000 lines per second
- Selectable min, max, center and deadband in Pulse and Analog modes
- Selectable exponentiation factors for each command inputs
- Trigger action if Analog, Pulse, Encoder or Hall counter capture are outside user selectable range (soft limit switches)
- Open loop or closed loop speed control operation
- Closed loop position control with encoder, analog or pulse/frequency feedback
- PID control loop
- Support for CANopen and two simplified CAN protocols
- Configurable Data Logging of operating parameters on RS232 Output for telemetry or analysis
- Built-in Battery Voltage and Temperature sensors
- Optional 12V backup power input for powering safely the controller if the main motor batteries are discharged
- Power Control wire for turning On or Off the controller from external microcomputer or switch
- No consumption by output stage when motors stopped
- Regulated 5V output for powering encoders, sensors, joysticks, RC radio, RF Modem or microcomputer
- Separate Programmable acceleration and deceleration for each motor
- Ultra-efficient 1.0 mOhm ON resistance MOSFETs
- Auto stop if no motion is detected
- Stall detection and selectable triggered action if Amps is outside user-selected range
- Short circuit protection with selectable sensitivity levels
- Overvoltage and Undervoltage protection
- Watchdog for automatic motor shutdown in case of command loss
- Overtemperature protection
- Diagnostic LEDs
- Efficient heat sinking using conduction bottom plate. Operates without a fan in most application
- Dust-proof and water-tight IP65 enclosure and connectors
- Power wiring via heavy duty M4 terminals terminals
- 5.50" (140mm) L, 4.45" W (113mm), 1.14" (29mm) H
- -40o to +85o C operating environment
- 440 g (0.96 lbs)
- Easy configuration, tuning and monitor using provided PC utility
- Field upgradeable software for installing latest features via the Internet

## Orderable Product References

| Reference | Number of Channels | Amps/Channel | Volts | FOC |
|-----------|--------------------|--------------|-------|-----|
| KBL1660   | 1                  | 120          | 60    | Yes |

## Important Safety Disclaimer

Dangerous uncontrolled motor runaway condition can occur for a number of reasons, including, but not limited to: command or feedback wiring failure, configuration error, faulty firmware, errors in user script or user program, or controller hardware failure.

The user must assume that such failures can occur and must make their system safe in all conditions. Roboteq will not be liable in case of damage or injury as a result of product misuse or failure.

## Power Wires Identifications and Connection

Power connections are made through high current screw terminals. A waterproof 8-pin M12 female connector provides connection to Hall or SSI rotor sensor. Communication and user I/O are located on the DSub15 connector.

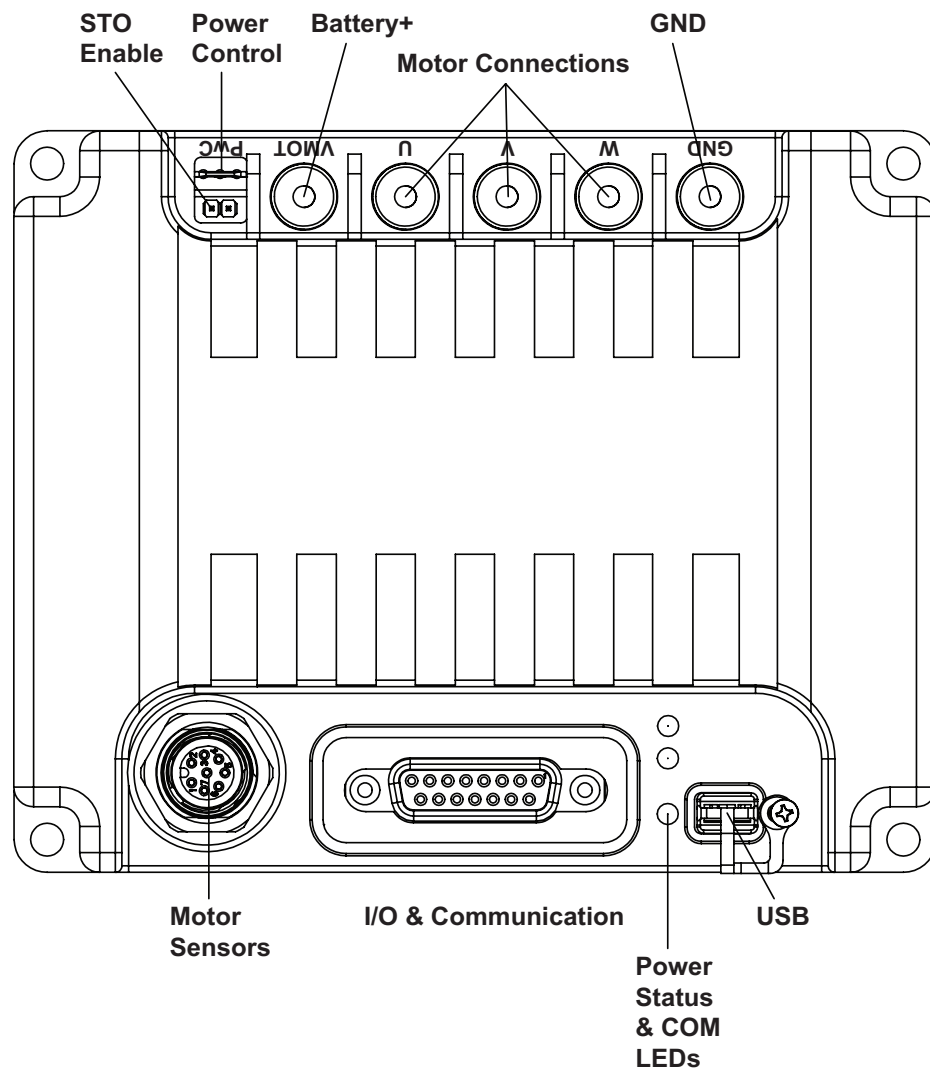

FIGURE 1. KBL1xxx Top View

Figure 2, below, shows how to wire the controller and how to turn power On and Off.

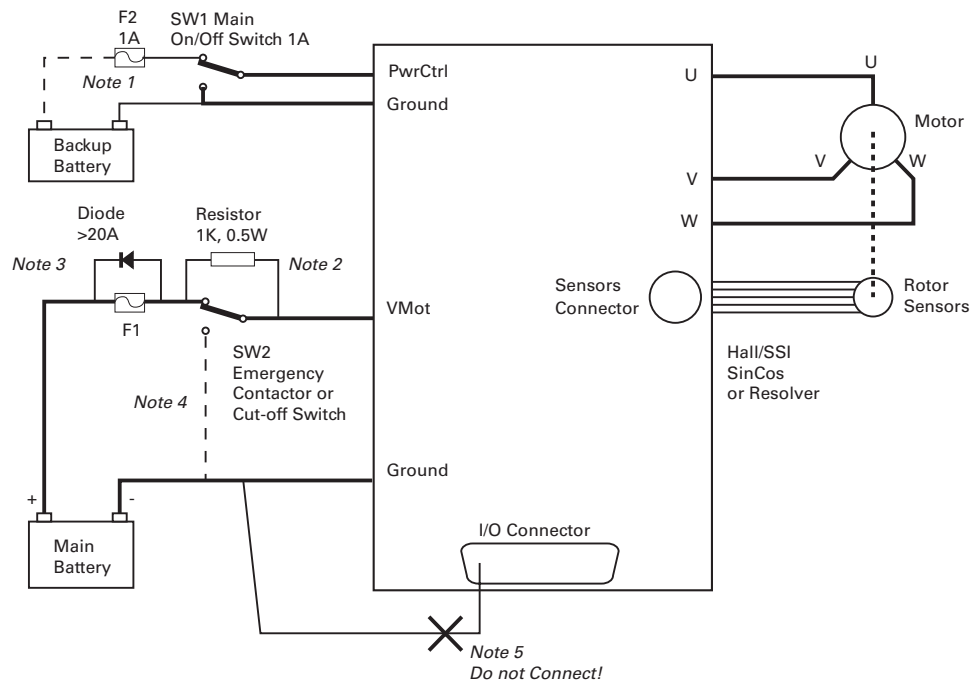

FIGURE 2. Powering the Controller. Thick lines identify MANDATORY connections

## Important Warning

**Carefully follow the wiring instructions provided in the Power Connection section of the User Manual. The information on this datasheet is only a summary.**

### Mandatory Connections

It is imperative that the controller is connected as shown in the above diagram in order to ensure a safe and trouble-free operation. All connections shown as thick black lines are mandatory. The controller must be powered On/Off using switch SW1 on the Power Control tab. Use a suitable high-current fuse F1 as a safety measure to prevent damage to the wiring in case of major controller malfunction.

### Emergency Switch or Contactor

The battery must be connected in permanence to the controller's VMot terminal via a high-power emergency switch or contactor SW2 as additional safety measure. The user must be able to deactivate the switch or contactor at anytime, independently of the controller state.

### Precautions and Optional Connections

Note 1: Backup battery to ensure motor operation with weak or discharged batteries, connect a second battery to the Power Control wire/terminal via the SW1 switch.

Note 2: Use precharge 1K, 0.5W Resistor to prevent switch arcing.

Note 3: Insert a high-current diode to ensure a return path to the battery during regeneration in case the fuse is blown.

Note 4: Optionally ground the VMot input when the controller is Off if there is any concern that the motors could be made to spin and generate voltage in excess of the controller’s absolute max voltage rating.

Note 5: Beware not to create a path from the ground pins on the I/O connector and the battery minus terminal.

## Controller Mounting

During motor operation, the controller will generate heat that must be dissipated. The published amps rating can only be fully achieved if adequate cooling is provided. Good conduction cooling can be achieved by mounting the controller to a metallic surface, such as the chassis, cabinet, etc.

## Motor Sensor Connector

The KBL1xxx is equipped with a waterproof, standard M12 female 8-pin connector for attaching the motor’s sensors, temperature sensor, and brake. Four of the connector’s pins are assigned a different functionality depending on the type of sensor use for rotor position feedback. Pin assignment is in the table below.

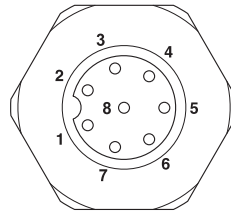

FIGURE 3. Motor Sensors Connector top view

TABLE 1.

| Pin Number   | 1     | 2      | 3      | 4      | 5     | 6    | 7         | 8   |
|--|-------|--------|--------|--------|-------|------|-----------|-----|
| Hall   | 5VOut | Hall A | Hall B | Hall C | NC    | Temp | Brake (1) | GND |
| SSI  | 5VOut | Clock+ | Data+  | Clock- | Data- | Temp | Brake (1) | GND |
| Sin/Cos  | 5VOut | NC     | SIN    | NC     | COS   | Temp | Brake (1) | GND |
| Resolver   | 5VOut | NC     | SIN    | NC     | COS   | EXC  | Brake (1) | GND |
| Note 1: Open Drain Output. Same as DOUT2 on Dsub connector |       |        |        |        |       |      |           |     |

### Connection to SSI Absolute Encoder

In Sinusoidal Mode, the controller can use motors equipped with absolute angle sensors with SSI interface. The controller issues an RS422-level differential Clock+/Clock- signal to, and receives a differential Data+/Data- signal from the encoder.

### Connection to Analog Sin/Cos Absolute Encoder

The KBL1XXX has two high-speed analog inputs that can be used to capture absolute angle position from angular sensors with sin/cos voltage outputs. The signal must be 0-5V max with the 0 at 2.500V.

## Connecting Resolver

Resolver wiring is similar to a Sin/Cos sensor with the addition of an excitation signal. Diagram below shows the necessary connections.

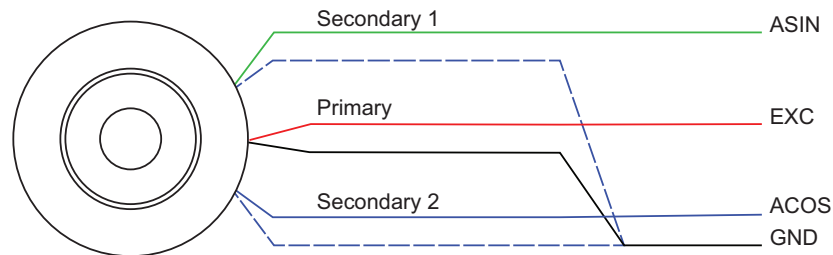

FIGURE 4. Resolver wiring

## Commands and I/O Connections

Connection to RC Radio, Microcomputer, Joystick and other low current sensors and actuators is done via the 15-pin connector located in front of the controller. The functions of many pins vary depending on controller model and user configuration. Pin assignments are found in Table 2, below.

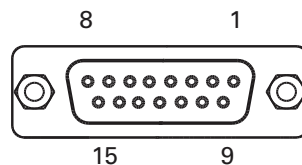

FIGURE 5. Connector Pin Locations

TABLE 2.

| Connector Pin | Power | Dout         | Com   | RC  | Ana  | Dinput        | Enc      | Default Config |
|---------------|-------|--------------|-------|-----|------|---------------|----------|----------------|
| 1             |       | DOUT1 (1)    |       |     |      |               |          | Unused         |
| 9             |       | DOUT2 (1)(6) |       |     |      |               |          | Brake          |
| 2             |       |              | TxOut |     |      |               |          | RS232Tx        |
| 10            |       |              |       | RC  | ANA5 | DIN5/STO1 (6) |          | AnaCmd (3)     |
| 3             |       |              | RxIn  |     |      |               |          | RS232Rx        |
| 11            |       |              | 485-  | RC4 | ANA4 | DIN4          |          | Unused         |
| 4             |       |              |       | RC1 | ANA1 | DIN1          | ENCA (2) | RCRadio1       |
| 12            |       |              | 485+  | RC3 | ANA3 | DIN3          |          | Unused         |
| 5             | GND   |              |       |     |      |               |          |                |
| 13            | GND   |              |       |     |      |               |          |                |
| 6             |       |              | CANL  |     |      |               |          | CAN Low        |
| 14            | 5VOut |              |       |     |      |               |          |                |
| 7             |       |              | CANH  |     |      |               |          | CAN High       |
| 15            |       |              |       | RC6 | ANA6 | DIN6/STO2 (6) |          | Unused         |
| 8             |       |              |       | RC2 | ANA2 | DIN2          | ENCB (2) | Unused         |

Note 1: Outputs are Open Drain. They pull to ground when on and float when off. Load must be connected between output and positive voltage.  
 Note 2: Encoder input requires RC inputs 1 and 2 to be disabled. Encoder is disabled in factory default.  
 Note 3: Analog command is disabled in factory default configuration.  
 Note 5: Remove STO Jumper to enable Safe Torque Off functionality  
 Note 6: DOUT2 is replicated on the M12 connector

For use in environments where liquid particles or fine dust may present, the controller's cover is shaped for DSub connectors with waterproof hoods. Product references EDAC 627-230-015-010 or Assmann A-DS15-HOOD-WP.

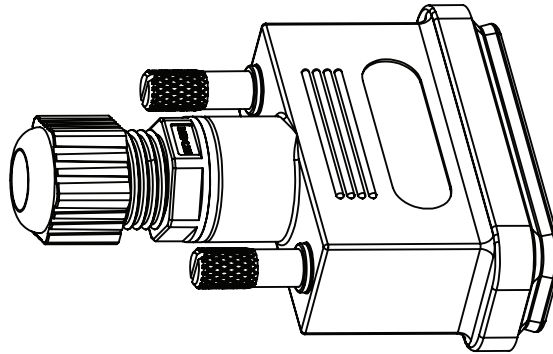

FIGURE 6. dsub15 waterproof shell

**Default I/O Configuration**

The controller can be configured so that practically any Digital, Analog and RC pin can be used for any purpose. The controller's factory default configuration provides an assignment that is suitable for most applications.

The figure below shows how to wire the controller to an analog potentiometer, an RC radio, the RS232 port, and the Digital output to a motor brake solenoid. You may omit any connection that is not required in your application. The controller automatically arbitrates the command priorities depending on the presence of a valid command signal in the following order: 1-Serial, 2-RC Pulse, 3-None. If needed, use the Roborun+ PC Utility to change the pin assignments and the command priority order.

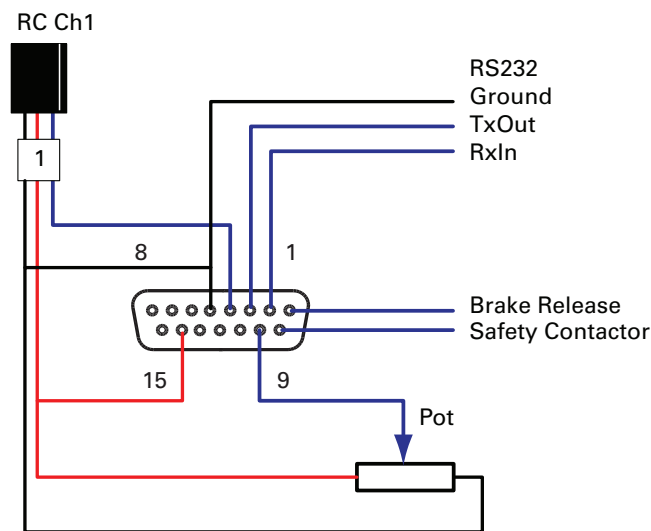

FIGURE 7. Factory Default Pins Assignment

## Enabling Analog Commands

For safety reasons, the Analog command mode is disabled by default. To enable the Analog mode, use the PC utility and set Analog in Command Priority 2 or 3 (leave Serial as priority 1). Note that by default the additional securities are enabled and will prevent the motor from starting unless the potentiometer is centered, or if the voltage is below 0.25V or above 4.75V. The drawing shows suggested assignment of Pot 1 to ANA1. Use the PC utility to enable and assign analog inputs.

## CAN Bus Operation

The controller can interface to a standard CAN Bus network, using 4 possible protocols: Standard CANOpen, and three proprietary schemes (MiniCAN, RawCAN and RoboCAN). Please refer to the User Manual for details.

## USB communication

Use USB only for configuration, monitoring and troubleshooting. USB is not a reliable communication method when used in a electrically noisy environments and communication will not always recover after it is lost without unplugging and replugging the connector, or restarting the controller. Always prefer RS232 communication when interfacing to a computer.

## Status LEDs and Flashing Patterns

The controller is equipped with three LEDs. A Green Power LED, a Red/Green Status LED and a Yellow Communication LED.

After the controller is powered on, the Power LED will tun on, indicating that the controller is On. The Status LED will be flashing at a two second interval. The flashing pattern and color provides operating or exception status information.



FIGURE 8. Normal Operation Flashing Patterns

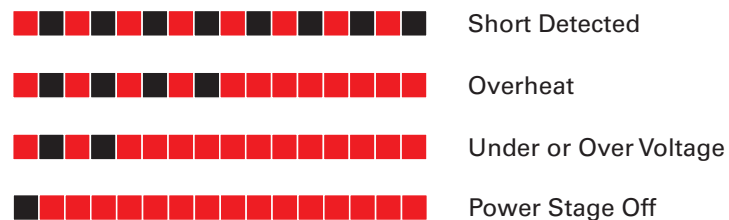

FIGURE 9. Exception or Fault Flashing Patterns



Additional status information may be obtained by monitoring the controller with the PC utility.  
 The communication LED gives status information on the CAN and USB.

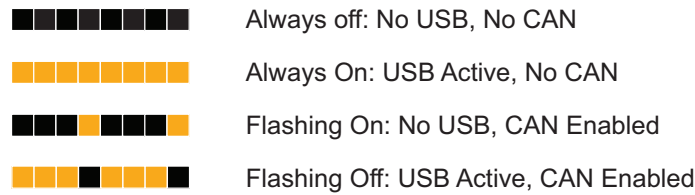

FIGURE 10. Communication LED Flashing Patterns

### Measured and Calculated Amps

The controller includes Amps sensors in line with the motor terminals and on the battery ground terminals. Both Motor Amps and Battery Amps are therefore measured with precision.

When motor is rotating, amps are AC. The KBL1XXX measures and is rated based on RMS Amps. The table below shows the relation between the RMS current and the DC Equivalent in Sinusoidal and Trapezoidal modes. In sinusoidal mode, DC equivalent are the amps resultant from the torque ( $I_q$ ) and quadrature ( $I_d$ ) vectors. In trapezoidal mode, they are the DC amps that flow through the two coils that are active at any one time.

|                    | <b>Amps RMS</b> | <b>DC Equivalent</b>       |
|--------------------|-----------------|----------------------------|
| <b>Sinusoidal</b>  | 120A            | 170A ( $I_{rms} * 1.414$ ) |
| <b>Trapezoidal</b> | 120A            | 147A ( $I_{rms} * 1.225$ ) |

### Safe Torque Off - STO (Certification Pending)

Safe Torque Off is a secure method for stopping the motor, regardless whether the controller is operating normally or is faulty. STO is Hardware-based, meaning that the MCU does not need to be processing the inputs or drive the motor outputs. When STO is enabled, two digital inputs, DIN5 and DIN6 are remapped as STO1 and STO2. Both inputs must have a 5V to 30V signal present at the same time in order for the Power MOSFETs to be energized. The controller will perform a self-check of the STO circuit at every power on. Once it is verified to work, the controller will safely turn the motors off if either input is below the 5V threshold, even in the case where any one component inside the controller is damaged. The STO circuit is verified and validated by TUV (certification pending) and can therefore be trusted in lieu of external relays.

By factory default STO is disabled. It must be enabled by removing the jumper located near the power terminals.

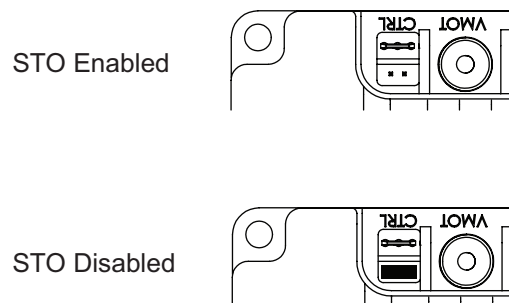

Figure 11. STO Enable jumper

## Electrical Specifications

### Absolute Maximum Values

The values in Table 3, below, should never be exceeded. Permanent damage to the controller may result.

TABLE 3.

| Parameter                         | Measure point                                    | Min | Typ | Max     | Units |
|-----------------------------------|--|-----|-----|---------|-------|
| Battery Leads Voltage             | Ground to VMot                                   |     |     | 62      | Volts |
| Reverse Voltage on Battery Leads  | Ground to VMot                                   | -1  |     |         | Volts |
| Power Control Voltage             | Ground to Pwr Control wire                       |     |     | 62      | Volts |
| Motor Leads Voltage               | Ground to U, V, W wires                          |     |     | 62 (1)  | Volts |
| Digital Output Voltage            | Ground to Output pins                            |     |     | 40      | Volts |
| Analog and Digital Inputs Voltage | Ground to any signal pin on 15-pin & Hall inputs |     |     | 30      | Volts |
| RS232 I/O pins Voltage            | External voltage applied to Rx/Tx pins           |     |     | 30      | Volts |
| Case Temperature                  | Case   | -40 |     | 85      | °C    |
| Humidity                          | Case   |     |     | 100 (2) | %     |

Note 1: Maximum regeneration voltage in normal operation. Never inject a DC voltage from a battery or other fixed source  
 Note 2: Non-condensing

### Power Stage Electrical Specifications (at 25°C ambient)

TABLE 4.

| Parameter                                 | Measure point                             | Min   | Typ       | Max     | Units        |
|---|---|-------|-----------|---------|--------------|
| Battery Leads Voltage                     | Ground to VMot                            | 0 (1) |           | 62      | Volts        |
| Motor Leads Voltage                       | Ground to U, V, W wires                   | 0 (1) |           | 62 (2)  | Volts        |
| Power Control Voltage                     |   | 0 (1) |           | 65      | Volts        |
| Minimum Operating Voltage                 |   | 9 (3) |           |         | Volts        |
| Over Voltage protection range             | Ground to VMot                            | 5     | 60 (4)    | 62      | Volts        |
| Under Voltage protection range            | Ground to VMot                            | 0     | 5 (4)     | 62      | Volts        |
| Idle Current Consumption                  | VMot or Pwr Ctrl wires                    | 50    | 100 (5)   | 150     | mA           |
| ON Resistance (Excluding wire resistance) | VMot to U, V or W.<br>Ground to U, V or W |       | 1.5       |         | mOhm         |
| Max Current for 60s                       | Motor current                             |       |           | 120 (6) | Amps         |
| Continuous Max Current per channel        | Motor current                             |       |           | 100 (7) | Amps         |
| Current Limit range                       | Motor current                             | 10    | 100 (8)   | 120     | Amps         |
| Stall Detection Amps range                | Motor current                             | 10    | 120 (8)   | 120     | Amps         |
| Stall Detection timeout range             | Motor current                             | 1     | 65000 (9) | 65000   | milliseconds |

| Parameter   | Measure point   | Min      | Typ      | Max      | Units        |
|---|---|----------|----------|----------|--------------|
| Short Circuit Detection threshold (10)  | Between Motor wires or Between Motor wires and Ground | 200 (11) |          | 500 (11) | Amps         |
| Motor Acceleration/Deceleration range   | Motor Output  | 100      | 500 (12) | 65000    | milliseconds |
| <p>Note 1: Negative voltage will cause a large surge current. Protection fuse needed if battery polarity inversion is possible</p> <p>Note 2: Maximum regeneration voltage in normal operation. Never inject a DC voltage from a battery or other fixed source</p> <p>Note 3: Minimum voltage must be present on VMot or Power Control wire</p> <p>Note 4: Factory default value. Adjustable in 0.1V increments</p> <p>Note 5: Current consumption is lower when higher voltage is applied to the controller's VMot or PwrCtrl wires</p> <p>Note 6: Max value is determined by current limit setting. Duration is estimated and is dependent on ambient temperature cooling condition</p> <p>Note 7: Estimate. Limited by heat-sink temperature. Current may be higher with better cooling</p> <p>Note 8: Factory default value. Adjustable in 0.1A increments</p> <p>Note 9: Factory default value. Time in ms that Stall current must be exceeded for detection</p> <p>Note 10: Controller will stop until restarted in case of short circuit detection</p> <p>Note 11: Sensitivity selectable by software</p> <p>Note 12: Factory default value. Time in ms for power to go from 0 to 100%</p> |   |          |          |          |              |

## Command, I/O and Sensor Signals Specifications

TABLE 5.

| Parameter  | Measure point              | Min    | Typ  | Max   | Units                  |
|--|----------------------------|--------|------|-------|------------------------|
| Main 5V Output Voltage   | Ground to 5V pin on DSub15 | 4.7    | 4.9  | 5.1   | Volts                  |
| 5V Output Current  | 5V pin on DSub15           |        |      | 100   | mA                     |
| Digital Output Voltage   | Ground to Output pins      |        |      | 40    | Volts                  |
| Digital Output Current   | Output pins, sink current  |        |      | 1     | Amps                   |
| Output On resistance   | Output pin to ground       |        | 0.75 | 1.5   | Ohm                    |
| Output Short circuit threshold   | Output pin                 | 1.05   | 1.4  | 1.75  | Amps                   |
| Input Impedances   | AIN/DIN Input to Ground    |        | 53   |       | kOhm                   |
| Digital Input 0 Level  | Ground to Input pins       | -1     |      | 1     | Volts                  |
| Digital Input 1 Level  | Ground to Input pins       | 3 (1)  |      | 30    | Volts                  |
| Analog Input Range   | Ground to Input pins       | 0      |      | 5.1   | Volts                  |
| Analog Input Precision   | Ground to Input pins       |        | 0.5  |       | %                      |
| Analog Input Resolution  | Ground to Input pins       |        | 1    |       | mV                     |
| Pulse durations  | Pulse inputs               | 20000  |      | 10    | us                     |
| Pulse repeat rate  | Pulse inputs               |        | 50   | 250   | Hz                     |
| Pulse Capture Resolution   | Pulse inputs               |        | 1    |       | us                     |
| Frequency Capture  | Pulse inputs               | 100    |      | 2000  | Hz                     |
| Encoder count  | Internal                   | -2.147 |      | 2.147 | 10 <sup>9</sup> Counts |
| Encoder frequency  | Encoder input pins         |        |      | 1M(2) | Counts/s               |
| <p>Note 1: STO lines active voltage is 5V min</p> <p>Note 2: Encoder input requires RC inputs 1 and 2 to be disabled. Encoder is disabled in factory default</p> |                            |        |      |       |                        |

## Operating & Timing Specifications

TABLE 6.

| Parameter   | Measure point            | Min   | Typ        | Max   | Units  |
|---|--------------------------|-------|------------|-------|--------|
| Command Latency   | Command to output change | 0     | 0.5        | 1     | ms     |
| PWM Frequency   | Motor outputs            | 10    | 16 (1)     | 20    | kHz    |
| Closed Loop update rate                                       | Internal                 |       | 200        | 40    | Hz     |
| RS232 baud rate   | Rx & Tx pins             |       | 115200 (2) |       | Bits/s |
| RS232 Watchdog timeout  | Rx pin                   | 1 (3) |            | 65000 | ms     |
| Note 1: May be adjusted with configuration program            |                          |       |            |       |        |
| Note 2: 115200, 8-bit, no parity, 1 stop bit, no flow control |                          |       |            |       |        |
| Note 3: May be disabled with value 0                          |                          |       |            |       |        |

## Scripting

TABLE 7.

| Parameter                   | Measure point | Min    | Typical | Max  | Units     |
|-----------------------------|---------------|--------|---------|------|-----------|
| Scripting Flash Memory      | Internal      |        | 32000   |      | Bytes     |
| Max Basic Language programs | Internal      |        |         | 3000 | Lines     |
| Integer Variables           | Internal      |        |         | 4096 | Words (1) |
| Boolean Variables           | Internal      |        |         | 8192 | Symbols   |
| Execution Speed             | Internal      | 50 000 | 100 000 |      | Lines/s   |
| Note 1: 32-bit words        |               |        |         |      |           |

## Thermal Specifications

TABLE 8.

| Parameter  | Measure point               | Min | Typ | Max    | Units |
|--|-----------------------------|-----|-----|--------|-------|
| Board Temperature  | PCB                         | -40 |     | 85 (1) | °C    |
| Thermal Protection range   | PCB                         |     |     |        | °C    |
| Thermal resistance   | Power MOSFETs to heats sink |     |     | 1      | °C/W  |
| Note 1: Thermal protection will protect the controller power                                 |                             |     |     |        |       |
| Note 2: Max allowed power out starts lowering at minimum of range, down to 0 at max of range |                             |     |     |        |       |

The KBL1xxx uses a conduction plate at the bottom of the board for heat extraction. For best results, attach firmly with thermal compound paste against a metallic chassis so that heat transfers to the conduction plate to the chassis. If no metallic surface is available, mount the controller on spacers so that forced or natural air flow can go over the plate surface to remove heat.

### Mechanical Specifications

TABLE 9.

| Parameter        | Measure point   | Min | Typ        | Max | Units   |
|------------------|-----------------|-----|------------|-----|---------|
| Weight           | Board           |     | 380 (0.84) |     | g (lbs) |
| Power Wire Gauge | Power Terminals |     |            | 8   | AWG     |

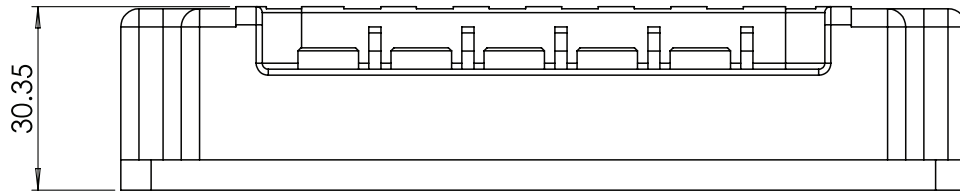

FIGURE 12. KBL1xxx Side View and Dimensions

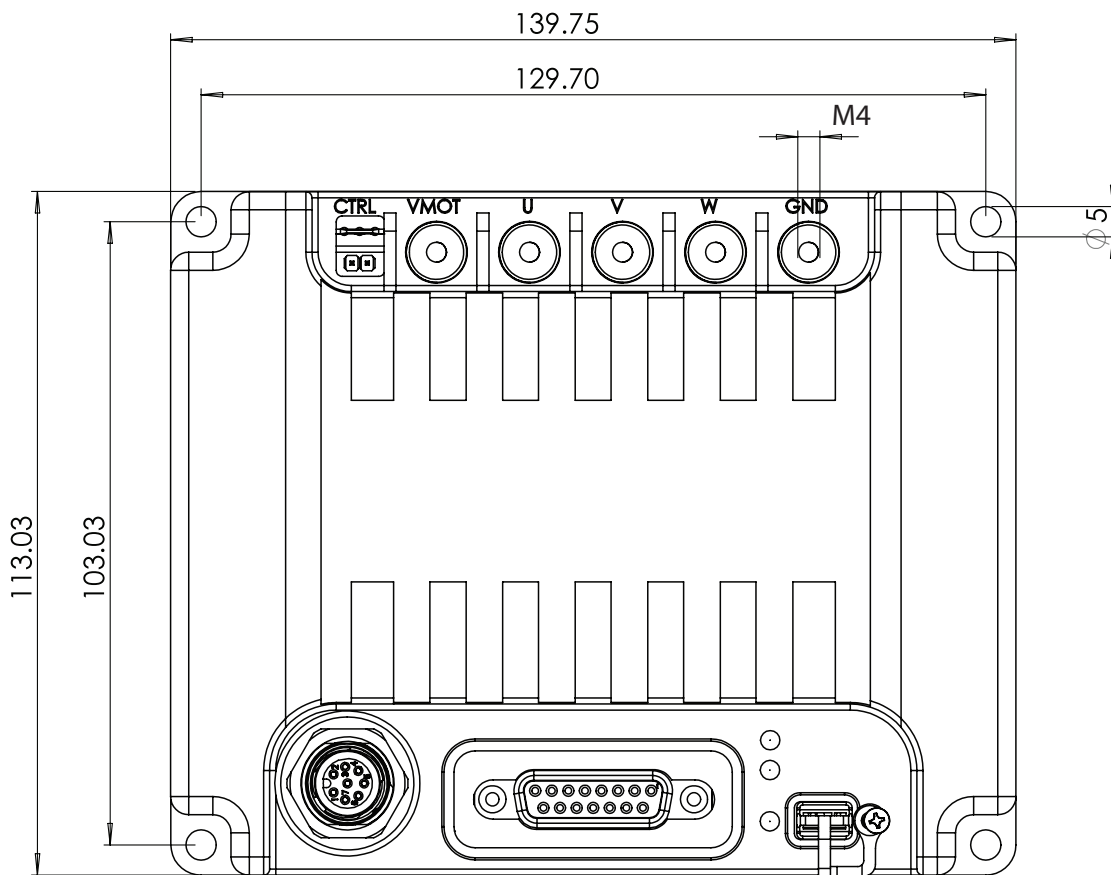

FIGURE 13. KBL1xxx Top View and Dimensions