

Color Camera Kit

The Camera Kit can give you a new perspective. Use this wireless color camera to see through your robot's eyes. Connect the Camera Receiver to any television to see and hear from your robot's point-of-view via the 2.4 GHz camera link.

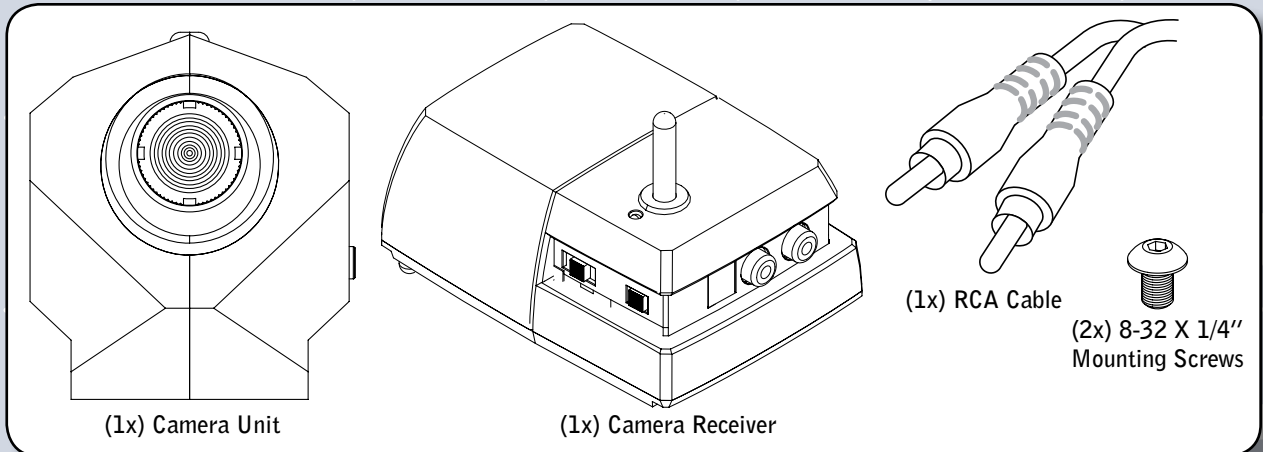

The first step is to insert the batteries into the Camera Receiver. Using a Phillips head screw driver, remove the screw and open the battery door on the bottom of the Camera Receiver. Install (4x) AA-batteries, not included. Insert the batteries in the correct orientation by following the polarity diagram inside the battery compartment. Reinstall battery door and screw.

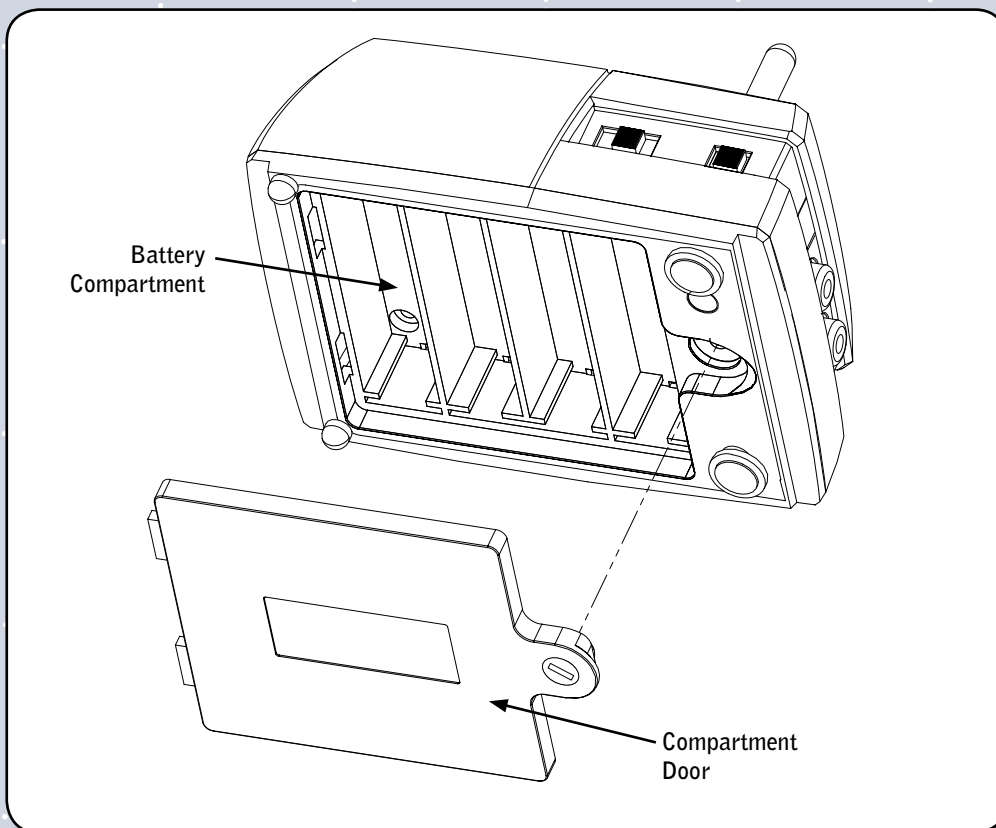

Limited 90-day Warranty
This product is warranted by Innovation First against manufacturing defects in material and workmanship under normal use for ninety (90) days from the date of purchase from authorized Innovation First dealers. For complete warranty details and exclusions, check with your dealer.

Innovation First, Inc.
1519 IH 30 W
Greenville, TX 75402

08/07

For More Information, and additional Parts & Pieces refer to:
www.VexRobotics.com

auxiliary accessories

Color Camera Kit, continued

Connect the Camera Receiver to a Television (not included) using the RCA Cable provided in the kit. Make sure the yellow connector is connected to the "Video" port on the Receiver, and the television, and the white connector is connected to the "Audio" port on the Receiver and the television.

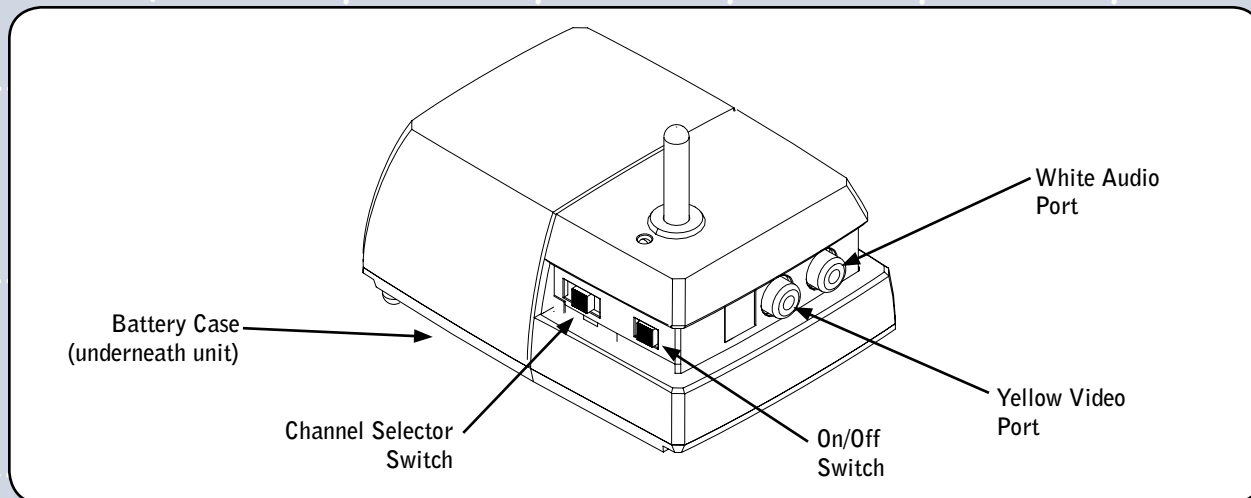

Once the Receiver has batteries installed and is connected to the TV, it is time to mount the Camera to your robot. The Camera has a row of (5x) threaded mounting holes on its bottom. These holes can be used to attach to Camera unit to any Vex structural component. The image below shows an example of camera mounting using the 2 Mounting Screws provided in this kit.

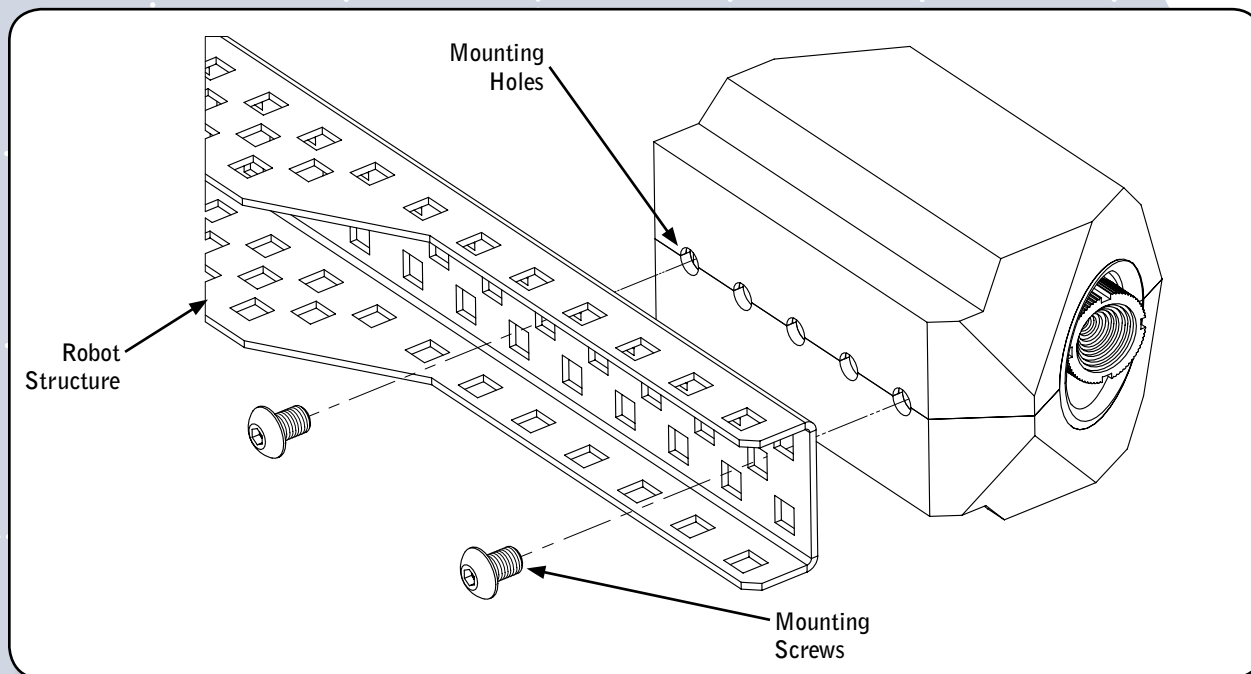

For More Information, and additional Parts & Pieces refer to:
www.VexRobotics.com

Color Camera Kit, continued

The Camera draws power from a power source; either a motor port on the Vex Microcontroller or from the "AUX" port on the Vex-RC Receiver. It has a 2-prong cable which can plug into either unit.

- a. When using the Vex Microcontroller - plug the 2-prong connector into a 3-pin socket so that the connector is against the flat edge (not the keyed edge) as shown. The key on the connector should NOT be inserted into the key of the socket.

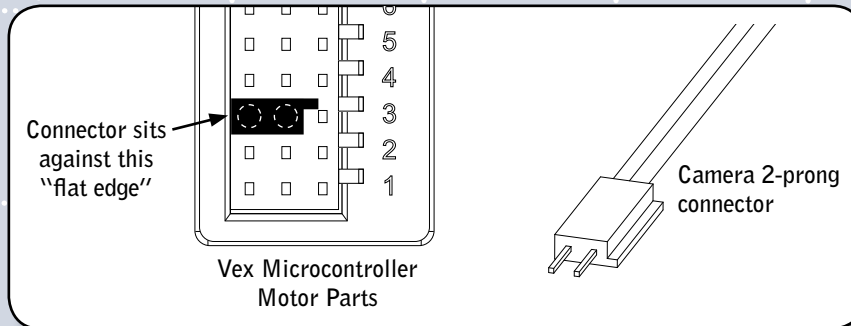

- b. When using the VEXplorer Receiver, simply insert the 2-prong connector into one of the 2-prong sockets of the Auxiliary port (AUX). It will only connect one way.

Note: The robot must be turned "on" for the Camera to receive power. You cannot have the robot turned "off" and still operate the camera.

Once the Camera is mounted and connected to power, it is time to turn the system on. Ensure that both the Camera unit and the Receiver are set to the same channel. (Each of these units has a "Channel Selector Switch", set these to the same number). Turn both units "on", and set the TV to the correct video input channel (this will vary, depending on the TV).

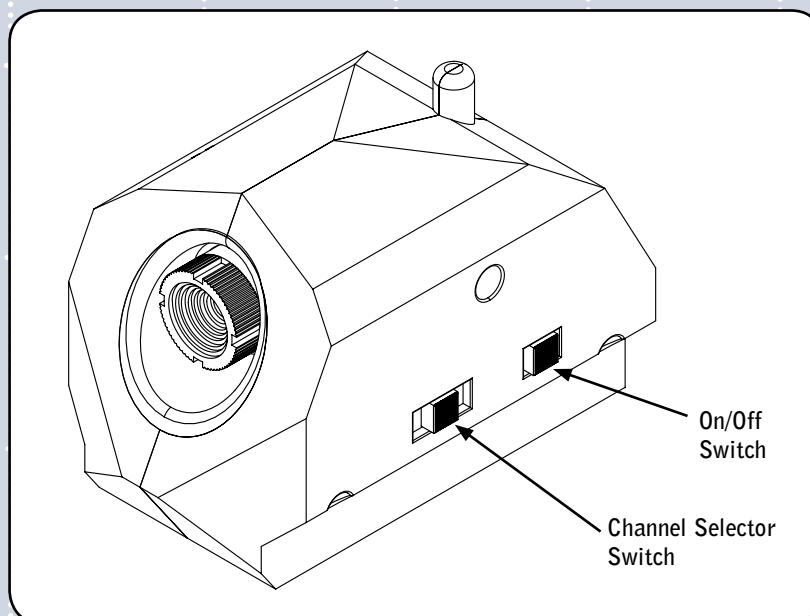

For More Information, and additional Parts & Pieces refer to:
www.VexRobotics.com

Color Camera Kit, continued

Camera Troubleshooting Guide:

Problem:

The LED light on the Camera Receiver is not "on".

Solutions:

1. Check your batteries to see if they have been installed correctly.
2. Check that batteries are charged.
3. Check that the power switch is in the "on" position.

Problem:

The LED light on the Camera Unit is not "on".

Solutions:

1. Check that the power switch on the Camera is in the "on" position.
2. Check that the Camera 2-prong connector is correctly connected.
3. Check that the robot is turned "on" and has fresh batteries.

Problem:

The LED light is activated on both the Camera Receiver and the Camera Unit, but I get no video.

Solutions:

1. Check that the RCA Video Cable is correctly attached to your television and to the Camera Receiver.
2. Check that your television is on the correct input channel (refer to your TV manual).
3. Check that the "Channel Selector Switch" on the Camera Unit and Receiver are set to the same number.

Problem:

The video quality is poor.

Solutions:

1. Check that the Camera is not too far away from the Receiver. The Camera will only work within a certain distance from the Receiver.
2. There may be interference from outside sources. Try changing the channel on the Camera and the Receiver to a different number, and see if the video quality improves. Note, the Camera and Receiver must both be set to the same channel.
3. The RCA Video Cable may be slightly disconnected, try disconnecting and reinstalling the cable for a better connection.
4. The RCA Cable may be damaged or broken. Try an alternate RCA cable.
5. The battery level on your robot or Camera Receiver is low, replace the batteries.

For More Information, and additional Parts & Pieces refer to:

www.VexRobotics.com