



## BL1500BP

### Sensored Brushless Motor Controller Single Channel

Roboteq's BL1500BP controller is designed to convert commands received from a R/C radio, Analog Joystick, wireless modem, or microcomputer into high voltage and high current output for driving one sensored brush-less motor. The controller is delivered with all necessary cables and hardware and is ready to use in minutes.

The controller interfaces to Hall sensors or optical sensors and it includes the +5Volt supply voltage that most brush-less motors require at their logic section.

The controller can be reprogrammed in the field with the latest features by downloading new operating software from Roboteq.

The BL1500BP is a variant of the AX1500; please refer to the Instruction Manual of The AX1500 for a full description of all common features.

#### Applications

- Heavyweight, heavy duty robots
- Terrestrial and Underwater Robotic Vehicles
- Automatic Guided Vehicles
- Electric vehicles
- Police and Military Robots
- Hazardous Material Handling Robots
- Tele-presence Systems

Key Features	Benefits
Voltage Range	12 to 40 volt
Current range	40 continuous-70peak Amp
Idle current	120 milli-Amp
Voltage available to Hall sensors	+5 Volt
Input modes	Analog RS232 Radio/PLM
External Output	24 Volt / 2 Amp 24 Volt not supplied internally
External Analog Input	0 – 5 volt
Thermal protection	Start at 85 oC-Full at 95 oC
Efficiency (series resistance)	10 milli-Ohm
Thermal resistance	2 oC/ Watt
Temperature Range	-40 to +85 oC
Terminations	Power screw in terminals 15 pin D sub connector Five terminal micro-board
Dimensions	4" x 4 x 1"
Weight	0.5 bs or 0.25 kilo

---

## Technical Features

### Microcomputer-based Digital Design

- Multiple operating modes
- Fully programmable using through connection to a PC
- Non-volatile storage of user configurable settings. No jumpers needed
- Field software upgradeable

### Multiple Command Modes

- Serial port (RS-232) input
- Radio-Control Pulse-Width input
- 0-5V Analog Voltage input (bi-directional)

### Automatic Command Corrections

- Joystick min, max and center calibration
- Selectable dead band width
- Selectable exponentiation factors for each command inputs
- 3rd R/C channel input for accessory output activation

### Special Function Inputs/Outputs

- One Switch input configurable as Emergency stop command
- One 24V, 2A output
- One digital input

### Built-in Sensors

- Hall effect sensor inputs.
- Voltage sensor for monitoring the external power 12 to 40V battery
- Voltage monitoring of internal 12V
- Temperature sensors near Power Transistor bridge

### Advanced Data Logging Capabilities

- 12 internal parameters, including battery voltage, captured command, temperature and Amps accessible via RS232 port
- Data may be logged in a PC or microcomputer

### Low Power Consumption

- On board DC/DC converter for single 12 to 40V battery system operation
- Optional 12V backup power input for powering safely the controller if the main motor batteries are discharged
- 120 milli-amp at 12V or 100mA at 24V idle current consumption
- Power Control wire for turning On or Off the controller from external microcomputer or switch
- No consumption by output stage when motors stopped
- Regulated 5V output for powering Hall Effect Sensors, R/C radio receiver. Eliminates the need for separate R/C battery.

### High Efficiency Motor Power Outputs

- Half bridge pahse drive for forward/reverse
- Ultra-efficient 5 milli-Ohm ON resistance MOSFETs
- 12 to 40 V operation
- User pre-settable current limit up to 60 A
- 16 kHz Pulse Width Modulation (PWM) output. Frequency can be adjusted for interference minimization

### Advanced Safety Features

- Over voltage and Under voltage protection
- Watchdog for automatic motor shutdown in case of command loss (R/C and RS232 modes)
- Run/Failure LED's display
- Programmable motors acceleration
- Built-in controller overheat sensors
- Dead-man" switch input
- Emergency Stop input signal and button

### Compact Design

- Efficient heat sinking.

---

## Stall control

- Brush-less motors have typically a low phase resistance and draw a substantial amount of current if stalled. Stall conditions may happen if a phase is accidentally disconnected or the phases are connected in the wrong order. To avoid damage to the motor or the controller, If no rotor movement is detected for more than 1/2 second after the power reaches 25%, the controller cuts off the current to the phases. It will then restart after throttling back the power to zero..

---

## Operating Instructions

### The motor

The motor must be a brush less sensed motor, meaning that the motor has a total of eight wires. Although the wire labels vary from motor to motor, typically they are:

- Three phase wires; labeled “S1, S2, S3” or “U, V ,W”
- Three sensor wires, labeled “A, B, C” or similar
- Ground labeled GND
- Input power to sensors labeled Vcc
- The Ground and Vcc wires are bundled with the sensor wires.
- The phases carry the current that operates the motor.

*Note: there is no standardization on the way phases and sensor lines are labeled by motor manufacturers. We refer in this document to phases as UVW and lines as ABC. Care should be exercised in relating the actual motor labels to our nomenclature.*

---

### The BL1500BP controller

The BL1500BP comes assembled on the basic AX1500 pc-board, being a variant of the AX1500. Consequently the caption on the PCB is “AX1500” followed by the version number. Although the BL1500BP and the AX1500 are two different products, they share the same identical PCB. Since the BL1500BP is a variant of the AX1500, please refer to the AX1500 instruction manual for the basic features of the product. As an example the AX1500 manual will explain in detail how to setup the controller options using the PC utility Roborun, how to drive the motor by radio, computer or analog signal etc.

---

### Connecting the BL1500BP to the motor

The BL1500BP comes with a five termination points micro-board. The terminations correspond to A – B – C – Vcc – GND.

The connections to the motor are implemented as follows:

- Power cable from positive power supply goes to Vmot (controller's power connector).
- Power cable from ground power supply goes to GND (controller's power connector ).
- Motor phase U goes to M1+
- Motor phase V goes to M1-
- Motor phase W goes to M2+
- M2- is left unconnected.
- Motor sensor wire GND goes to the termination GND on the BL1500BP micro-board.
- Motor sensor wire Vcc goes to the termination Vcc on the BL1500BP micro-board.
- Motor sensor wire A, B, C go to the terminations A, B, C on the BL1500BP micro-board..

Use Roborun to connect to the BL1500BP. Roborun reports it as “Single Channel” since only one motor can be driven. To setup please perform the following steps:

- The controller is shipped in “Default” setup. In doubt make it “Default” by using Roborun “Default” button and saving to controller.
- Default sets the controller to “Radio”. Change it to Analog or RS232 as needed.
- Set the current limit slightly above the max operating current of the motor. Brush-less motors may stall for many reasons. If a prolonged stall condition happens, there will be damage to the motor and possibly to the controller.

---

## Powering the board

It is possible that the first time the motor is connected it will not spin if the phases are not connected to the controller power connector in the proper order. The motor may stall, or behave erratically or spin only in one direction.

In this event the motor may draw a large amount current, capable of damaging the motor or the controller; for this reason when connecting the motor for the first time mount a fast fuse rated at the maximum motor current on the battery positive wire; As an additional precaution put a power resistor in series with the fuse, to limit the current. A typical value is 1 Ohm / 25 Watt.

Once the installation has been completed and the motor spins, the resistor is no longer needed, while the fuse should be kept.

---

## Spinning the motor

The initial connection to the motor should be done with the motor shaft unconnected to a mechanical load. Spin the motor using Roborun Channel 1.

If after making the first connection the motor does not spin, exchange the position of the Phase wires U, V, W until the combination that makes the motor spin is found.

Check that the motor spins in both directions.

---

## Notes

- Many hobby brush-less motors are “sensorless”. The BL1500BP cannot drive them. The BL1500 is designed for professional Hall Effect sensed motors.
- Many sensed brush-less motors have the A, B, C sensor lines “open collector”. The BL1500BP incorporates pull-up resistors, so there is no need to add them.
- The BL1500BP is a single motor, single channel device. Use only Channel One commands on Roborun.
- Most sensed brush-less motors accept a wide range of Vcc (4 to 20 Volt). The +5Volt provided by the BL1500BP is fully adequate.
- The motor wires labeled GND, Ground or Vcc, +5 Volt etc. are not outputs; they are power inputs and accept the Ground and +5 Volt connection from the BL1500BP.
- Roborun allows to change the Acceleration Rate. This will visibly affect how fast or how slow the motor accelerates slows down after a “change speed command” is issued to the controller

- In the event the micro-board is removed, please make sure it is reinserted with the pin one aligned with the pin 1 of the underlying 10 pin header. Pin 1 is denoted by its shape (a square shape instead of the usual round shape).

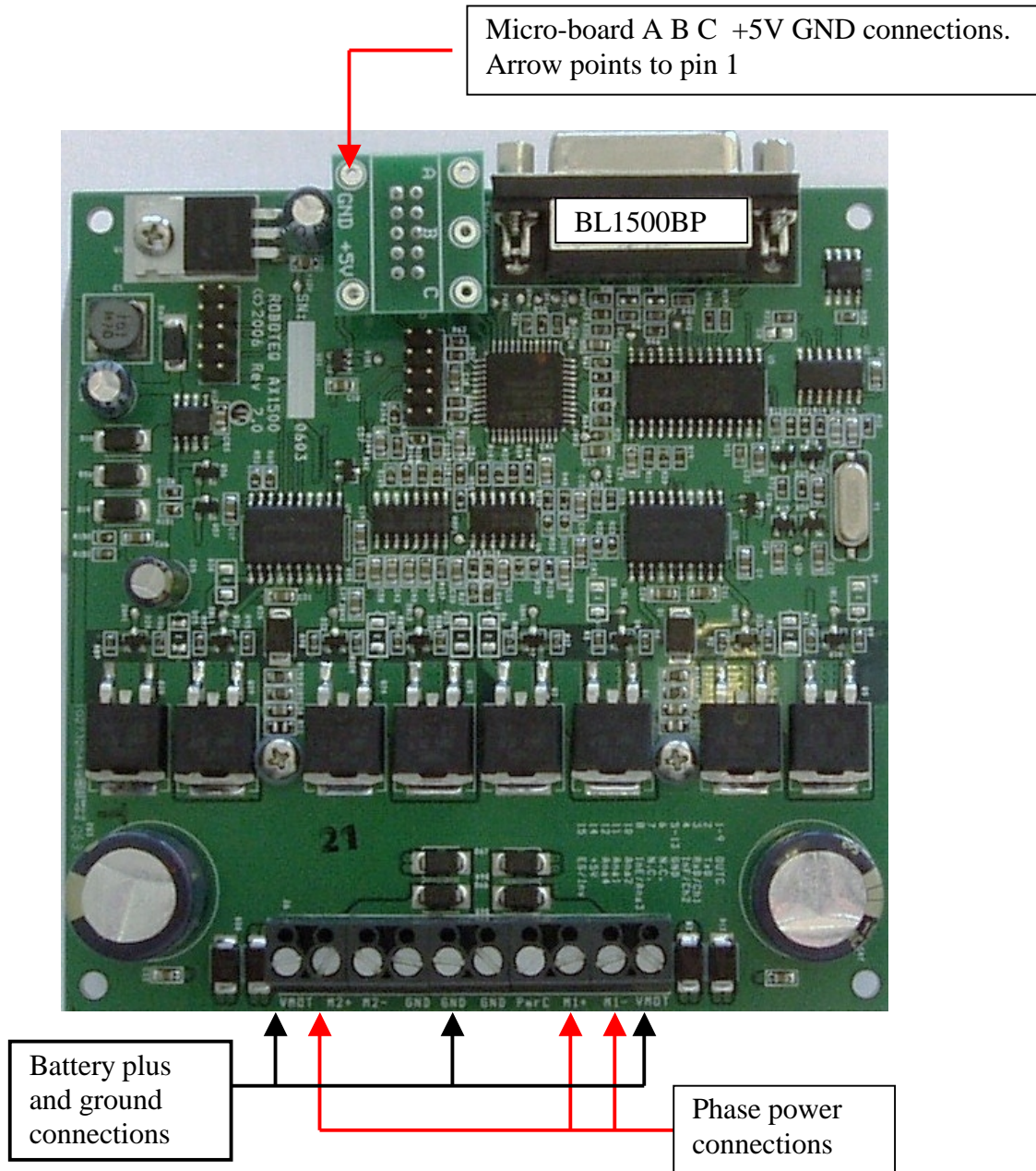

Phase relationship between phases U V W and sensors A B C

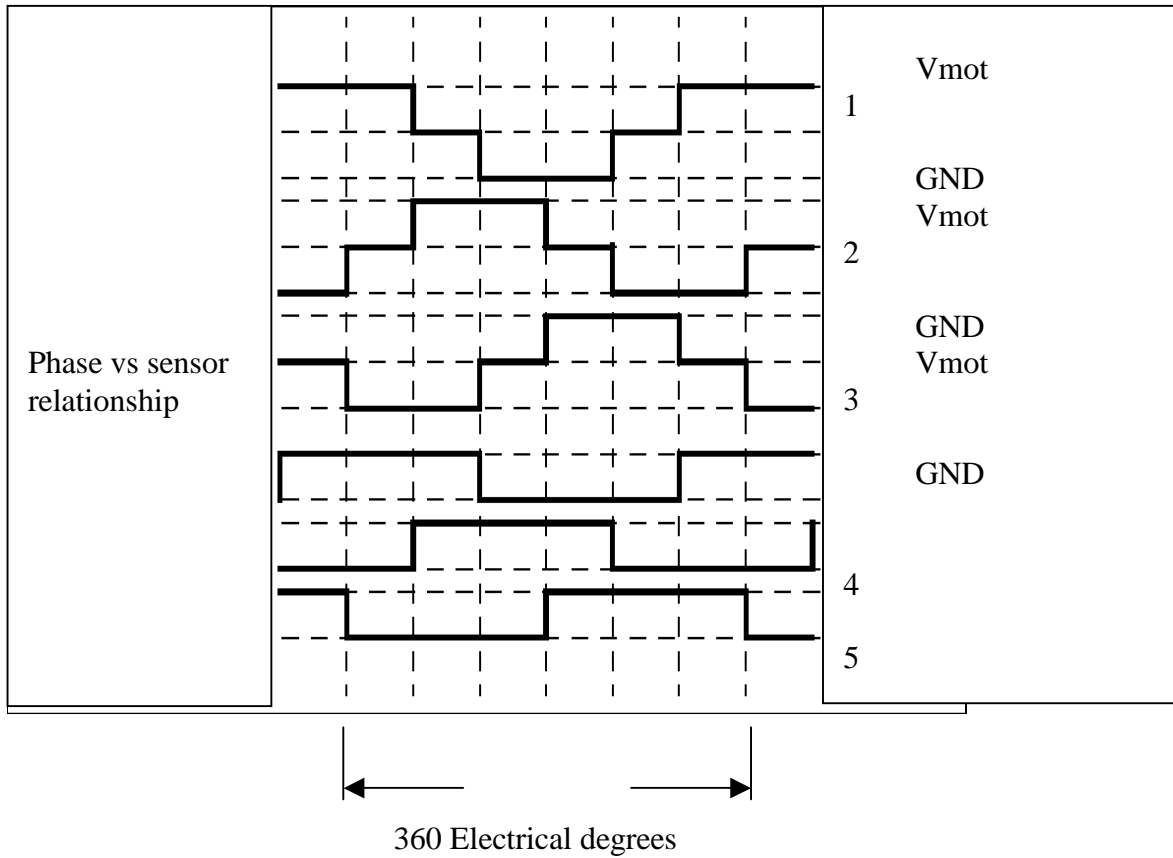

waveform1 – Phase U voltage  
 waveform 2 – Phase V voltage  
 waveform 3 – Phase W voltage

waveform 4 – Sensor A input to the controller  
 waveform 5 – Sensor B           "  
 waveform 6 – Sensor C           "

The phase waveform has three values: Vmot / Floating / Ground

Phase current will traverse the phase in one direction or the opposite direction depending on the voltage applied.. The level shown to be intermediate between Vmot and Ground is not an actual level but rather the symbolic indication that the phase is open so no current goes through it.

We recommend to use the BL1500 internal +5Volt power supply to feed the motor's sensors block. In this case the sensor signals are logic TTL levels.

Most motors are eight poles motors, meaning that one mechanical revolution (360 mechanical degrees) of the motor corresponds to four electrical rotations of the phases. Motors may also be available as four pole implementation. Please note: many different symbols are used for phases and sensor outputs. Refer to the datasheet of the motor for the exact nomenclature.

Ordering Information

Model	Description
BL1500BP	Single Channel Sensored Brushless DC Motor Controller .