

PDX16/26

STANDARD SHAFT:
4140 HARDENED STEEL
0.500 DIAMETER
0.125 KEYWAY TO SHAFT END
#10-32 END TAP, 0.300 MIN DEPTH

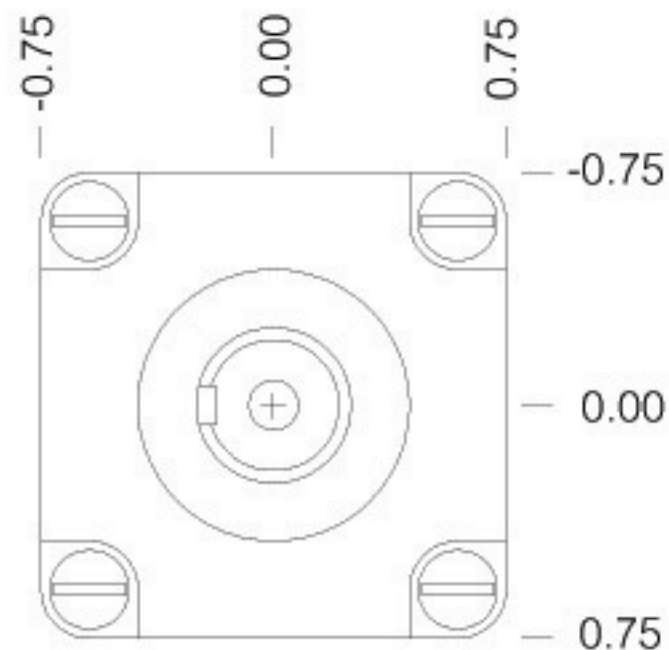
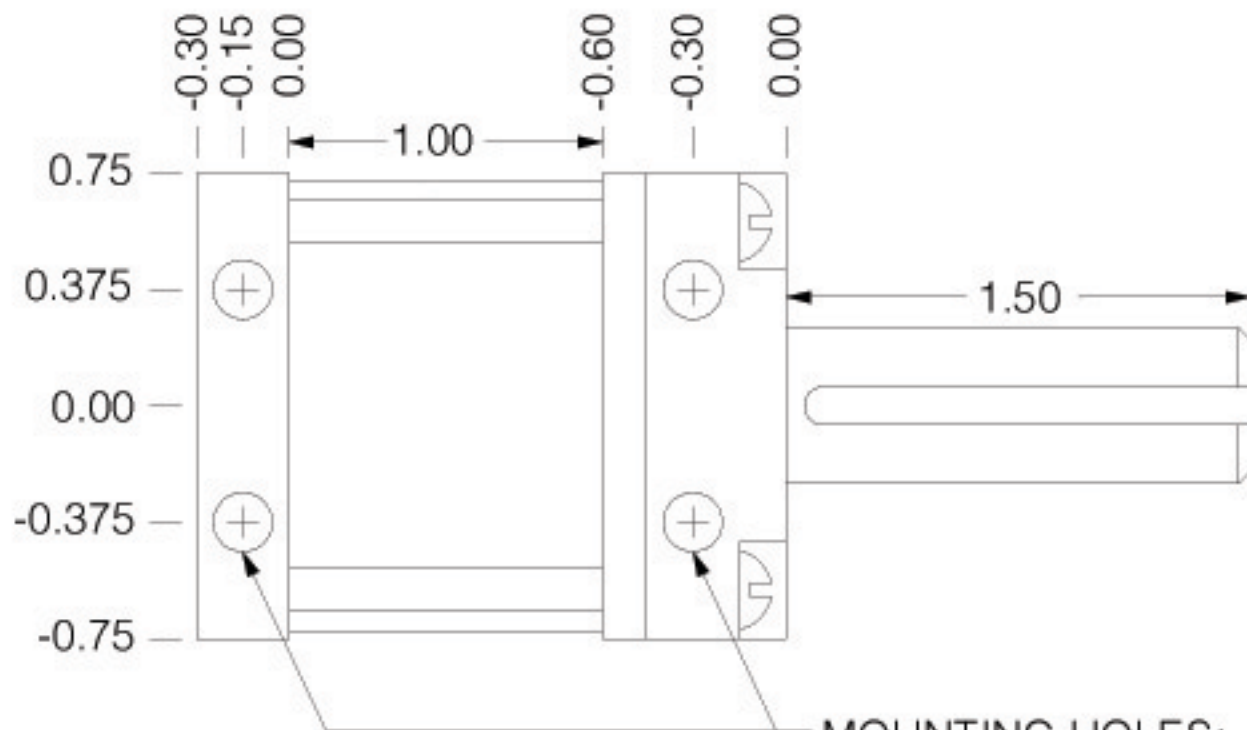

ALL DIMENSIONS INCHES
NO HIDDEN LINES SHOWN

MOUNTING HOLES:
#10-32
8 TOTAL
4 TOP, 4 BOTTOM
0.30 MIN DEPTH

PRELIMINARY
11 JAN 09