

MOSFETs

MOSFETs do fail occasionally, but in practise failures are very rare. They are doing an enormous amount of work and sometimes one simply gives up: commonly the drive MOSFETs cause their drive resistors to burn up - a sure sign the MOSFET has failed.

Relay drop-out

A flat battery or wiring which is too thin can cause excessive voltage drop. If the supply voltage gets to low then, on the 24v controllers, the battery discharge protection operates and reduces controller performance.

On the 12v controllers, discharge protection is not fitted as standard - so the internal 9v rail can drop. If

19 Service & Guarantee

All 4QD's products carry the normal 12 month guarantee. Outside the guarantee period, or when the fault is caused by misuse, we will repair the controller at a fixed price.

Service charge, Pro-120 £22.50

If the fee is prepaid, 4QD will pay VAT but if an invoice has to be raised, carriage and VAT will be charged extra.

20 Other products

4QD manufacture a full range of controllers: from our Eagle and 1QD series through to our high current 4QD series (up to 300 amps, 48v) as well as a range of extras such as LED voltmeters for 12v and 24v, joystick interfaces and a timer for 'stand-off' operation in golf caddies. We also manufacture controllers for golf caddies, golf buggies, kiddie cars, wheelbarrows, conveyors and other battery motor uses.

it does, the relay will drop out, switching off the controller. The controller will work happily down to 10.5v (the minimum you should discharge a battery).

Sticky relays.

The power relays are switched by the controller at low current so are very reliable. However a wiring error can cause an arc at the contacts which are delicately balanced against the spring to maximise contact pressure. So a small arc can, on occasion, cause a relay to stick. If a relay does not click when expected, it is worth tapping it with a screwdriver handle, to see if it is sticking.



"We're in Control"

See us via the Internet:

<http://www.4QD.co.uk>

4QD

Office Stores

30 Reach Road

Burwell

Cambridgeshire, CB5 0AH

Fax: 01638 744 080

<http://www.4QD.co.uk>



"We're in Control"

Email to: support@4QD.co.uk

Instruction Manual

Pro-120 series controllers

Mark 2 series

Foreword

4QD try to write a manual which is readable. Please read the manual through before starting installation.

To help you, we have marked the more technical sections ¶ so that you may ignore them.

This manual covers installation and wiring of 4QD's Pro series controller in the usual applications. There are finer points of installation which are outside the scope of such a printed manual and you should refer to our www site for more information.

Applications

4QD's Pro range of 4 quadrant controllers are well suited to general purpose speed control applications where reversing is required. They are used extensively by hobbyists and industry.

Amongst other applications our controllers have been successfully used in the following:

- Camera dollies
- Caravan shifters
- Carnival floats
- Conveyors
- Factory stores vehicles
- Floor cleaning machines
- Golf buggies
- Invalid scooters
- Kiddie cars
- Miniature railways, 3", 5" and 7¼ gauge
- Mobile targets
- Mountain rescue vehicles
- Remote controlled vehicles (Robots)
- Ride on golf buggies
- Winches

In fact wherever battery motor speed control is required

Models

The Pro-120 is available either for 24v operation or for 12v operation. Models can also be supplied for 36v and 48v

The voltage is marked on the relays. Make sure this are correct as 24v relays will not operate from 12v and 12v relays will soon burn out if used on 24v.

The standard model is suitable for permanent magnet or shunt wound motors.

21 More information

A manual such as this cannot cover all the points everyone may need to know. If you require more information, the best source is 4QD's Internet site, where there is a wealth of 4QD technical information on motor control.



"We're in Control"

4QD

Office Stores

Unit 6A

Heath Road Industrial Estate

Burwell

Cambridgeshire, CB5 0AP

<http://www.4QD.co.uk>

Email to: support@4QD.co.uk

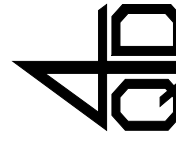

"We're in Control"

See us via the Internet:

<http://www.4QD.co.uk>

Email to: support@4QD.co.uk

4th November 2003

Contents

| | Section |
|--------------------------------|---------|
| Introduction | 1 |
| Safety | 2 |
| Features | 3 |
| ¶ Specifications | 4 |
| Mounting | 5 |
| Connections | 7 |
| Power Connections | 8 |
| Battery wiring | 8.01 |
| Motor wiring | 8.02 |
| Circuit breaker | 8.03 |
| Battery condition meter. | 8.04 |
| Controls | 9 |
| Speed pot | 9.01 |
| ¶ Use as voltage follower | 9.02 |
| Ignition (On/Off) switch | 9.03 |
| ¶ High Pedal lock-out | 9.04 |
| ¶ Battery Discharge Protection | 9.05 |
| Reversing switch | 9.06 |

1

4QD's NCC-Pro-120 is a reversing motor speed controller for battery operated vehicles covering currents up to 120 amps (over 150 amps peak). They are available for operation on voltages ranging from 12v to 48v. They are high frequency chopper drivers giving control of motor speed both in drive mode and in braking mode. They use MOSFETs in state-of-the-art high frequency circuitry to give best possible performance and battery economy. The controllers incorporate many advanced features such as reverse polarity protection, regenerative braking, independent, linear, adjustable acceleration and deceleration ramps, controlled performance at power down, reverse speed reduction, dual ramp reversing, pot fault protection and electromagnetic brake driver. Many of these features can be disabled if so required.

2 Safety

Handling - Important!

Before handling the controller, disconnect the batteries and short out the controller's battery input terminals. This will discharge the main capacitors, which otherwise can store charge for many hours. If any foreign body contacts the board while these capacitors are still charged, the controller may be damaged.

17 Disabling Regen Braking

There are few applications where regenerative braking is deleterious and it should normally be left engaged. However it is possible to disengage it.

When regen braking is disengaged

- 1: the controller **must** be also switched to pre-select reversing (section 9.08)
- 2: Chose a long deceleration ramp setting, as the

motor will brake only under friction.

Failure to do this will cause jerky performance and may burn out the relays.

To deactivate regen braking, remove the **two** links shown as BR1 and RB2 on the features diagram, page 4.

18 Common faults

There are no 'common' faults: as soon as 4QD find a fault which occurs often enough to recognise it as a problem, we try to alter the design to eliminate it. This makes it difficult to give you sensible fault finding tips - but it does improve our product!

Most controllers returned for attention are either nor faulty or have been damaged by 'foreign bodies': nuts and bolts in the works or water etc.

There's a lot more service and fault finding info on our www site: www.4QD.co.uk

Controller appears to be dead

Check the High Pedal lockout and the pot you are using. HPLO and pot fault detector are intended to **detect faults** and *stop the controller from working*.

Controller switches off erratically

The protection circuitry will switch the controller off in the event of a fault: faults inside the controller are rare and generally are no erratic: the controller works or it fails.

Parking brake is use: if this is faulty or is drawing too much current, the controller will switch off and this will seem erratic.

Otherwise: if too low a pot value is used or some other device draws current from the pot supply, a fault will be detected.

Fuse and fuse tracks

These are present to prevent major damage to the controller is there is an **external wiring fault**.

They are two special sections of track which should blow if a major fault occurs in the controls or the brake (connected to the 6 pin and 3 pin input

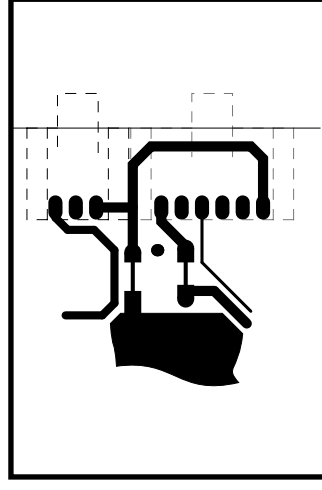

it blow, then you should fit the fuse shown in the 'Connections' diagram, page 7. Use a 1 amp fuse.

Overheating

Beware of sustained overheating: the heatsink can operate up to 95°C but not more (the overheat sensor will operate). The main decoupling capacitors may get warm, but should not be allowed to remain too hot to touch for too long.

The other limit is the soldering to the relays: the current is limited just below that required to cause the solder to melt!

IDC wire size

Some problems are caused by the use of the wrong wire size or type in the IDC connectors. Wire that is too thin may make poor contact. If it is too thick(16/0.2) it may cause shorts. Single stand wire can break.

15 Waterproofing

The cover is a vacuum forming which is waterproof. The circuit board is varnished - this resists humidity and condensation. The cased assembly is best mounted with the heatsink at the bottom: water may run over the aluminium base with no problem - in fact water on the base would have to be about 10mm deep before it touched anything electrically live.

In the mouth of the cover you should fit a splash plate (supplied with the cover) in the position shown in diagram 6. The splash plate should be sealed/glued in place with suitable silicone rubber (Dow Corning 734 RTV) between plate and circuit board. Run a fillet of rubber along the top edge of the plate and push it up to the relays. Leave the assembly board-side down while the rubber sets so that it runs down to the circuit board forming a seal. When supplied as a controller with case, 4QD will fix the splash plate in position.

The cover has a strip of foam already fitted to help sealing between cover and board. However you must not let water get onto the board - at the very least electrolytic corrosion will occur - so take a moment to consider what will happen if water runs down the leads to the controller: put a kink in the leads so water drops off at that point.

If mounting the controller on its side, remember that if water gets into the mouth it could sit inside the controller and could easily touch the circuit board. Either make sure water cannot enter or else drill a drainage hole in the bottom side of the cover, at the mouth, so water can escape. We also suggest you seal the splash plate to the side of the cover with silicone rubber.

16 Choice of motor

All speed controllers should only be used with good quality motors. Motors with damaged, worn brushgear will cause arcing. On occasion brush arcing can cause seemingly random controller failure. This effect is quite rare, but be careful.

Ideally the motor should include an internal suppression capacitor, a ceramic type of 10n value is ideal. If the motor does not include this you are advised to fit one across the brushes as close as possible to the motor body. The controller will work without this capacitor, but fitting it can lengthen the life of the system.

A word of warning: many car type motors have the chassis connected to one terminal. Take great care with these as you could easily short the controller out - which would be fatal. It is best to avoid these motors. Otherwise either make sure the motor is mounted on insulation (including the drive shaft), or make certain that no other point of the control system can be earthed to chassis.

Most modern d.c. motors use permanent magnets. These are the best for battery operation. However, other types can be used: at 4QD we regularly use a 12v car starter motor for testing (even with our 24v 150 amp drives) since these are a far worse load than is ever likely to be met. Into such a motor (stalled)

controller down, slowing the machine. When the controller's output stops switching (i.e. at zero speed), the power relay switches off.

Reversing on the Pro series controllers is normally 'dual ramp' but can be changed to 'pre-select' by removing a jumper on the board.

Dual Ramp Reversing means that, when the reversing switch is operated at speed, the controller slows down under control of the deceleration ramp, automatically reverses when motor speed gets near zero and accelerates again under control of the acceleration ramp. If the ramp controls are set for quick response this process can be quite violent. Also, reversing is done by monitoring the demand speed (after the ramping circuit) and not by measuring the motor voltage. Therefore, if the vehicle is reversed when going down a hill, motor will still be rotating and the vehicle will be travelling when reversing occurs. Reversing can therefore be accomplished on any hill but it will be more or less violent depending on the setting of the ramp controls. The user is however best advised therefore not to reverse at speed. We make no guarantees about the mechanical effects!

Pre-select Reversing

Dual ramp reversing can be disabled on-board, when the reversing becomes pre-select. The selected direction will only be engaged when the throttle pot is advanced from zero. If pre-select is used with a joystick the controller will not reverse unless the stick is held at zero until the motor has stopped.

Regen Braking

Regenerative braking is very reliable. However, it works by feeding power back into the battery. If your battery is already fully charged then regen braking may have difficulty in operating as it has to overcharge the battery. A similar problem exists if the battery is disconnected, or the wiring faulty. There are several options as to how the controller should react under such fault conditions so if in doubt, ask!

In any case, all passenger carrying vehicles should be fitted with mechanical brakes: it is unwise to rely on the battery as an emergency brake!

Charger Inhibit

Some machines have in-situ battery charging. Other

machines are designed so that the batteries have to be removed for charging. Where the batteries are left connected during charging, it may be considered desirable to stop the user driving off before disconnecting. This is the function of 'Charger inhibit'.

The Pro-120 has no separate inhibit input, so it is necessary to be a little clever with the existing inputs. You can use a switched socket for the charger. This is a socket with an auxiliary switch which is broken when the (charger) plug is inserted. Such a break switch should be wired in-series with the ignition switch, so the ignition cannot be activated when the charger is connected.

Failing this, you can use a third pin on the charger connector, wired as shown below.

When the charger is inserted, the link is made, shorting the wiper of the throttle pot to battery negative. Even if the ignition is now switched on, no

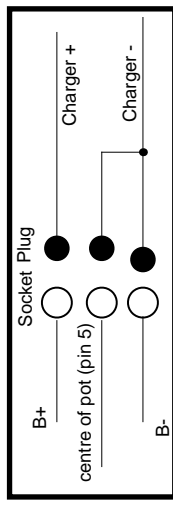

speed can be selected so the machine cannot drive.

The female part should be on the vehicle with its sockets arranged so no metal object can touch them when the charger is unplugged.

Many 3 pin connectors have one pin advanced so that it is the first contact to make when the plug is inserted. This pin should be battery negative since, if any other pin made contact, battery positive could be applied back to the pot wiper with destructive consequences!

3 Features

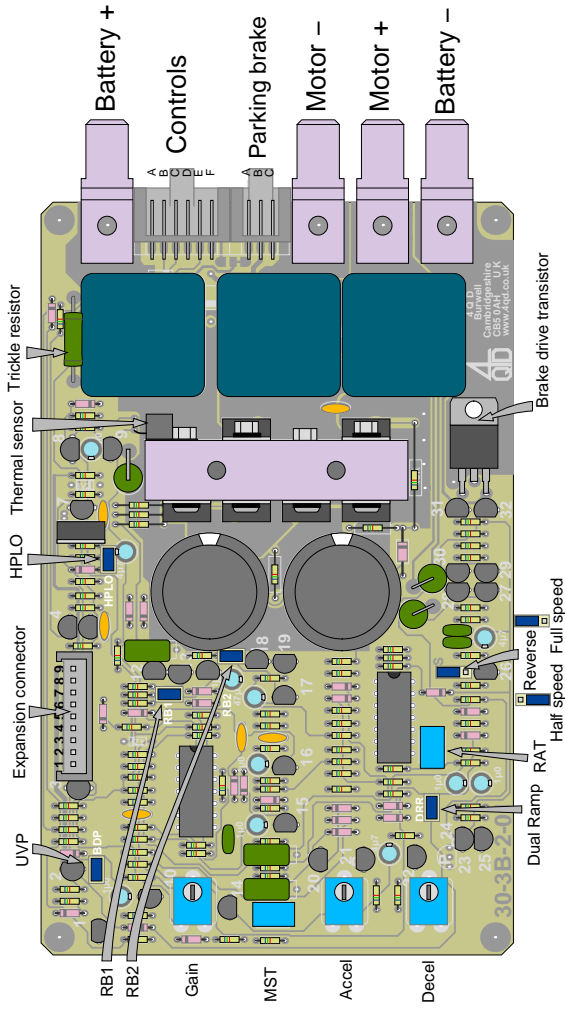

For shipping, the mating parts of the 'Controls' and 'Parking brake' connectors are inserted into the sockets on the board. See page 7.

The Pro-120 has double 9.5mm motor tabs, for one or two motors and single 9.5mm battery tabs. Also fitted on the battery terminals is a set of 6.3mm blades, to connect a charger or for similar purpose. These are illustrated below.

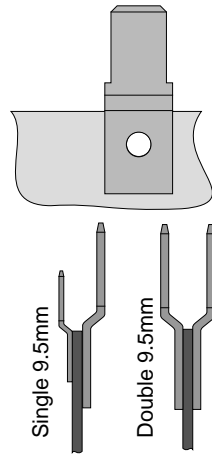

Also available is an expansion connector option as shown above, see section 12.

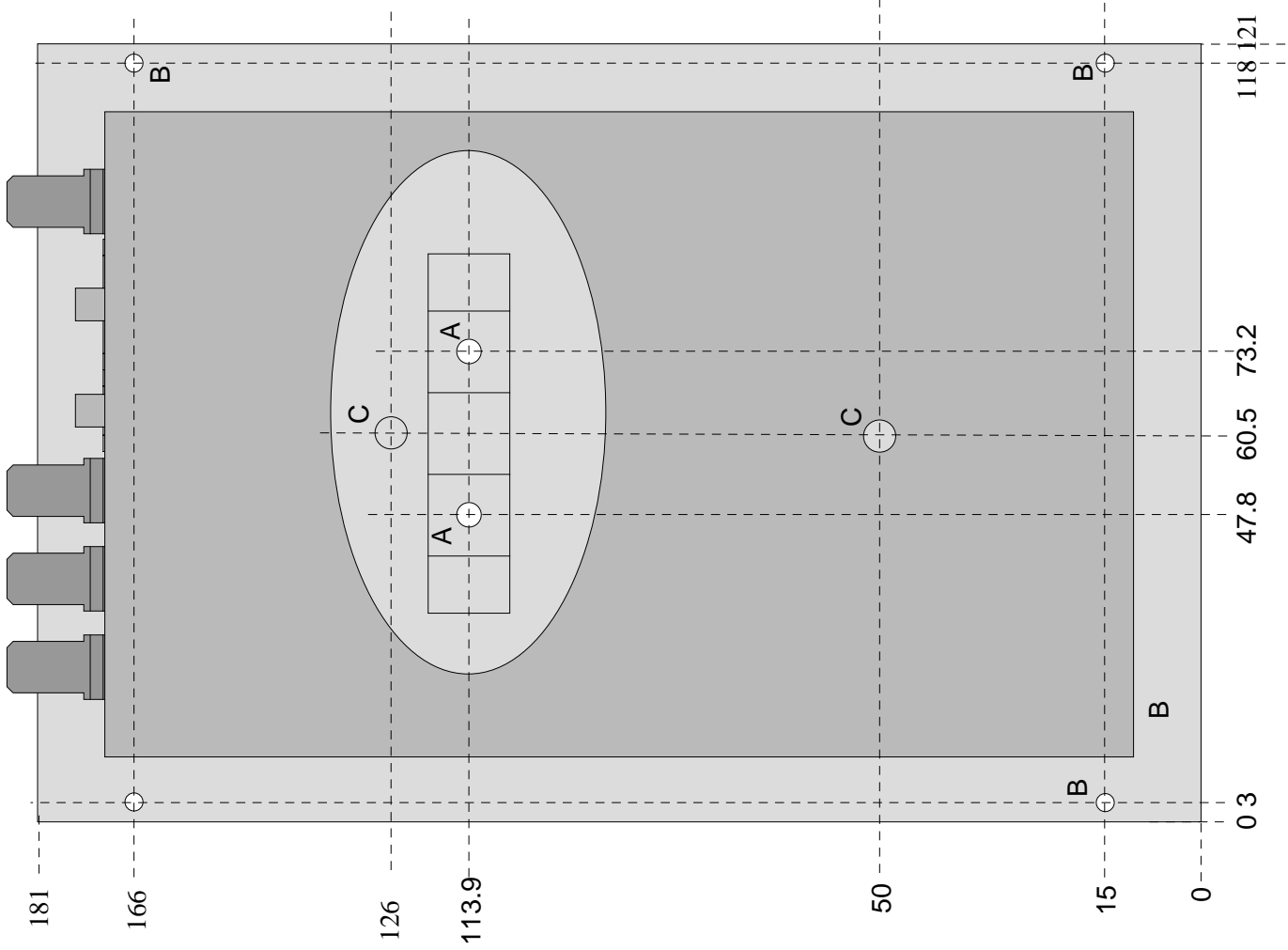
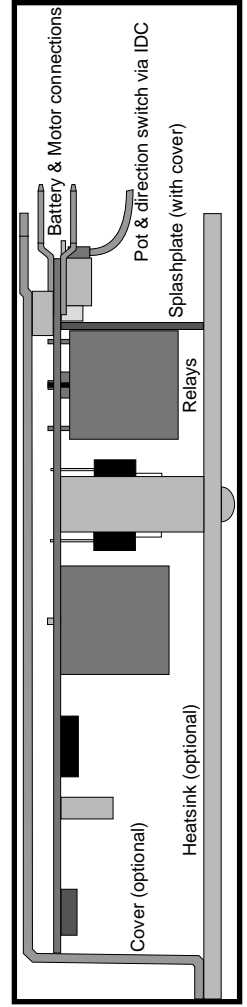

| Feature | Section | Page |
|-------------------------------|---------|------|
| High Pedal Lockout | 9.04 | 8 |
| Battery Discharge Protection | 9.05 | 8 |
| Reverse speed | 9.07 | 9 |
| Dual ramp/Preselect reversing | 9.08 | 9 |
| Regenerative Braking | 17 | 15 |

There are also several user adjustments:

| | | |
|--------------|-------|----|
| Gain | 11.01 | 10 |
| Acceleration | 11.03 | 10 |
| Deceleration | 11.03 | 10 |
| RAT | 11.04 | 11 |
| MST | 11.04 | 11 |

13 Heat & Heatsinking

The long time current the controller can give is limited by the build up of heat in the heatsink. The controller will give over 10 amps for one minute - this is limited by the heatsink and by heating in the printed wiring, relays and other components. For periods of more than a minute you need an external heatsink to remove heat. The available continuous current will depend on this external heatsink.

Steel is not a good heatsink material: heat does not flow easily in steel. Aluminium or copper is far better. If you have a steel plate, sandwich an aluminium sheet between the steel and the Pro to

spread the heat.

For really arduous use we suggest heatsink compound between the Pro's heatsink and your own: this helps heat flow across the join. Make sure both surfaces are flat and free of grit.

NCC-Pro-120 incorporate a thermal sensor which cuts back the output current if the controller gets too hot (95°C) so the available current is (only) about 25 amps. At this current the MOSFETs will dissipate about 20 watts. This is still enough to keep the heatsink hot so don't rely too heavily on it!

14 Base and cover option.

(facing page)

The diagram shows the dimensions of 4QD's base which is available as an option.

Two A holes are for mounting the Pro-120's heatsink onto the base plate.

Four B holes are for mounting the cover.

Two C holes are mounting holes in the baseplate.

The board is shown cut away (the oval hole) to show the position of the Pro 120's heatsink block.

Base and cover are available separately so you may use your own base.

The cover is supplied with four plastic 'push rivets' which locate in the 'B' holes.

Alternatively the cover may be fixed by using double sided adhesive tape around the rim of the cover.

4 Specifications

Supply voltage 12v or 24v or 36v or 48v different models
Supply current 30mA at zero speed
Motor speed 0 to 100% full speed adjustable
0 to 50% full Or as forward speed On board option
in reverse

Output current (typical)

Current limit 125 amps min 155 typical
1 minute rating 100 amps without additional heatsink!
2 minute 60 amps without additional heatsink!
continuous 30 amps or more: heatsink dependant.
With no heatsink, over heat typically occurs after 15 minutes at 30 amps.
Regenerated current limit 100 amps minimum.
Overheat temperature 95° on heatsink
Overheat current 25 amps typical, factory adjustable
Switching frequency 20kHz approximately
Size 160 x 102mm x 40mm board only
Weight 325g
Input 5k to 25k pot. adjustable
Input voltage 3v minimum for full speed tripped
Parking brake driver 1 amp max
Pot fault detect greater than 30K adjustable
Acceleration time 330mSec to 7 Sec adjustable
33mS to 0.7 Sec (-RW version) adjustable
330mSec to 7 Sec adjustable
Deceleration time 33mS to 0.7 Sec (-RW version) effectively inactive
15v adjustable
Battery discharge Protection 50mV ¶ ‡ 100mV max ‡
Relay Activate Threshold (RAT) 300mV ¶ ‡ 600mV max ‡
Modulation Start Threshold (MST)

¶ factory setting.

‡ measured on modulator input - pin 6 of expansion connector.

5 Mounting

The NCC Pro is designed for mounting via the heatsink as in the diagram (facing page). This also shows a section through the optional base and cover. This mounting will normally be on to a metal chassis which will act as additional heatsinking but, in most applications, full current is only drawn for short periods so little heating will be experienced.

However, the Pro's heatsink is a thick block of aluminium which won't cool down quickly to the air if it does get hot so some heatsinking should be used. A suitable metal plate which will usually be the vehicle's chassis.

For sustained high current use you must use a substantial extra heatsink with heatsink compound on the joint between the Pro's block and your heatsink. The Pro 120's heatsink is not connected to

the rest of the circuitry. Mounting holes are tapped M3. You can also mount the controller in a diecast aluminium box, e.g. Eddystone 26827PS.

Optionally a base/heatsink and cover is available for the NCC-Professional - see section 14.

Corner mounting holes are also provided if required but the additional support is unnecessary so we recommend mounting only by the heatsink.

Whatever you do, make sure the controller can't get wet and, if it does, *don't connect the battery* until you have dried the controller thoroughly. The water won't cause damage unless the unit is connected to the battery, when electrolytic corrosion will occur. See also section 15.

7 Connections

The diagram shows the simplest connections needed to use the controller.

More information on wiring follows.

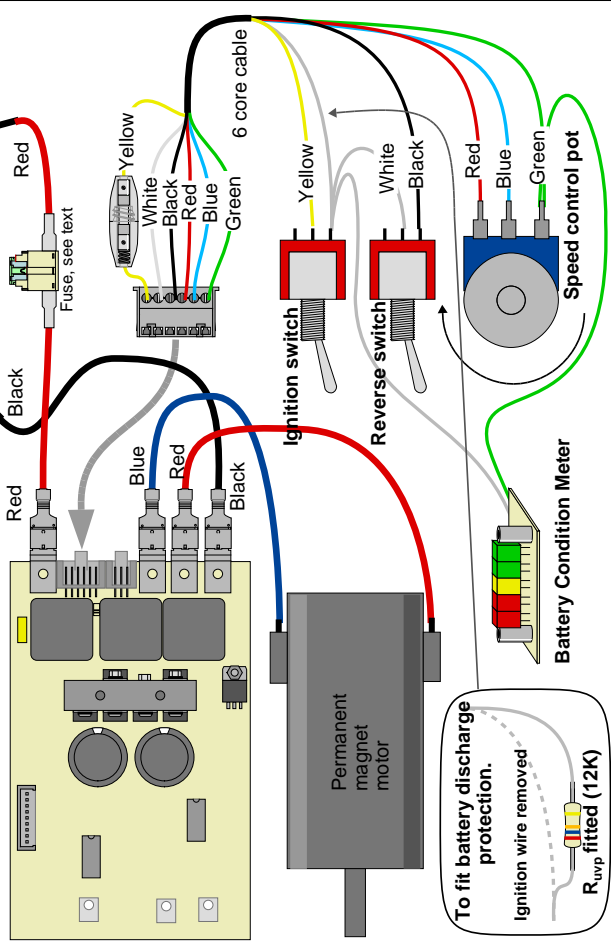

Yellow is directly connected to battery +ve. White and black may also be battery +ve (depending on the control switches). Green is battery -ve and blue and red are the control pot.

Fuse in yellow wire is optional but recommended - see p 15.

8 Power Connections

8.01 Battery wiring

Battery connections to the controller are shown in the diagram above. Use only good quality battery connectors: the controller feeds current back the battery during braking and if a battery connector falls off when braking this regenerated current can pump up the voltage on the dud battery connection. Although the controller is protected against damage, this is not advised since control is lost. The same will happen if a fuse or circuit breaker opens during braking.

Wire size.

Use heavy duty wire for the battery leads and make them as short as possible. This also applies to the battery linking wire on 24v systems.

4mm (12awg) wire is 'officially' rated to handle 41 amps continuously. At 100 amps it gets too hot to touch within about 60 seconds. We therefore suggest you use at least 6.0mm² (10awg) wire for battery connections.

On the 12v controllers, voltage loss in the wire is important and you may need to use two lengths of 6mm² wire for the battery - depending on their length. Excessive voltage loss will cause the voltage

point, the parking brake is released.

MST. As the throttle is further advanced then, normally just above the RAT, the controller starts to modulate: i.e. it starts switching and voltage is fed to the motor. This is the MST (Modulation Start Threshold).

Because of stiction in the motors, they need a small voltage before they start to rotate: this will occur at a slightly higher throttle setting.

Full speed is reached approximately 3v above the MST (measured on pin 6 of expansion connector).

In certain applications, altering these adjustments can make for better low speed control, near zero speed. For instance, increasing RAT could suppress relay jitter in a radio control application.

12 Expansion connector

Pin numbers are printed on the circuit board.

The two controllers will work as one, controlling the two motors together with the gain and ramp adjustments of the master controlling both.

The two motors will perform identically but with independent current limits. If two motors are used off one single 200 amp controller, then the full 200 amps current is available to drive either motor in stall conditions. With the Pro-120, each motor may stall. The system therefore offers more protection to the motors. Also, if one motor gets disconnected, the second motor will still be protected. Lastly, if there is a failure in one controller the chances are that the vehicle may still be operable on the other controller, providing an emergency 'get you home' service, albeit at reduced performance.

Other Uses

The expansion connector is designed to allow additional facilities to be fitted - so there are many possibilities!

Note that the expansion connector on issue 7 boards is slightly different from earlier issues!

Double heading

When two standard controllers are used, one is the master the second is the slave. This combination might be used, for example, in an electric railway for 'double heading' a train with one engine at each end. The controller which is to be the slave should have its ignition switched off, it will be controlled by the master.

The slave controller need have only battery connections and connections to the second motor. It is connected to the master Pro by a 6 way cable between the two expansion connectors. This cable should join as follows:

| Master | Slave |
|---------|------------------|
| pin 1 - | pin 1 |
| pin 2 - | do not connect |
| pin 3 - | pin 3 |
| pin 4 - | pin 4 (optional) |
| pin 5 - | pin 5 |
| pin 6 - | do not connect |
| pin 7 - | pin 7 |
| pin 8 - | do not connect |
| pin 9 - | pin 9 |

11 Adjustments

Do not use excessive force when adjusting the presets: these are quite small and are easily damaged.

11.01 Gain

This is marked 'Gain' on the diagram 'Features'. Set this so that, at maximum required pot range, the controller just reaches full speed: this is easiest to do with the motor unloaded. Set the speed pot to your required maximum point (e.g. full up) then, listening to the motor, adjust the preset. It is usually quite easy to tell when the motor stops accelerating. Too low a setting and the motor will not reach full speed (this can be useful to restrict top speed).

Too high a setting and there will be a 'flat' spot at maximum speed where the control has no effect. This will also confuse the special 'power down' circuitry so you will get a bumpy ride if you switch off at speed.

Maximum setting of the gain preset will give full output for about 3v input. The sensitivity can be increased by fitting a resistor: contact the factory for details.

11.02 Full speed

Where user adjustment of the top speed is required the 'gain control' is not satisfactory. In this case the arrangement below can be used.

Both pots should be the same value (10K). The resistor shown in the green lead to the top speed adjust pot is optional: if left out (open-circuit) the top speed will adjust between 50% and 100%

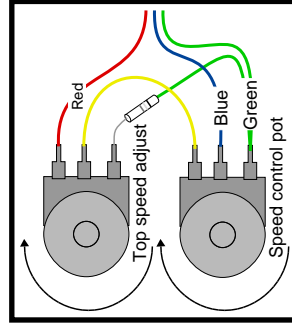

resistor
none 50% - 100%
10K 33% - 100%
4K7 25% - 100%
3K3 20% - 100%
2K2 15% - 100%
1K2 10% - 100%
linked: 0% - 100%

Alternatively, you can simply fit a resistor in the top of the pot (red wire) but the value of this resistor plus the pot should not exceed 20K.

11.03 Ramps

The Pro series controllers incorporate very sophisticated ramps to control the acceleration and deceleration rates. These are user adjustable and, to get best performance from your machine, you should adjust them!

Acceleration ramp

This is shown as 'Accel' on the 'Features' diagram. It is present to make the vehicle accelerate smoothly when the speed pot is increased suddenly so as to avoid sudden surges and shocks to the mechanics. As supplied it is at half setting so that the motor takes about 3 seconds to accelerate. Adjust it as you require to give smooth acceleration. Clockwise increases the time (reduces the acceleration) anticlockwise decreases the time (increases the acceleration) If the time is set too short (anticlockwise) the vehicle's acceleration will be limited by the current limit which does no harm (except that repeated accel/decel will cause over heating) but it means that acceleration is not being controlled properly, so will vary depending on the gradient.

Deceleration ramp

This is shown as 'Decel' on the Features diagram: it is present to make the vehicle decelerate smoothly when the speed pot is reduced suddenly. As supplied it is at half setting (about 3 seconds). Adjust it as you require to give smooth deceleration. You will usually find you require a lower setting (more anticlockwise) for Decel than for Accel. If the Decel time is set too low (anticlockwise) then the relays will drop out and short out the motor before regenerative braking has finished. This may give a jerk before the vehicle stops completely and may also shorten the life of the relays.

11.04 RAT and MST

Two other presets exist: we advise against altering these.
Normal setting is centre scale.
Another sensible setting is with both fully clockwise.

RAT. As the throttle is moved from zero, at a low setting one or other direction relay engages (depending on the selected direction). This is the RAT (Relay Acceptance Threshold). At the same

at the controller to fall so low that the controller detects a fault condition and the relay will switch off.

On the 24v versions, use of wire that is too long (and/or too thin) will cause loss of power but will not harm the controller although the decoupling capacitor (see 'features' diagram above) may heat up. Heat will shorten the operating life of capacitors.

Crimp Contacts

You must use fully insulated crimps: the power connections are close to each other and uninsulated crimps may short out and cause damage. Best of all use 'F type' crimps with vinyl covers. 4QD can supply these pre-crimped only as they require a special crimp tool.

8.02 Motor wiring

This is not quite so critical as battery wiring: too long and/or too thin wire will cause a loss of performance, it will get and will waste battery power but will not damage the controller. However, wire which is too thick will do no harm either so we recommend the same wire for the motor as for the battery.

8.03 Circuit breaker

A circuit breaker may be fitted if required. The main advantage is that it will enable the battery or motor to be disconnected in the event of an emergency or for security. A circuit breaker will not protect the drive in the event of a fault: MOSFETs fail far faster than a circuit breaker can operate.

You could fit a breaker in the battery lead: take care not to increase the wiring length too much. Also, certain types of breaker can have the same effect as increased battery lead length. A breaker in the motor may therefore be best: it will enable you to quickly disconnect the motor in an emergency. Also with the motor disconnected, freewheeling becomes possible. It is also possible to get a battery isolator switch - these are normally fitted to lorries, buses and boats to isolate the battery in an emergency - but this is not required as the Pro-120 has a power relay which effectively disconnects the battery (except for a small bleed resistor).

8.04 Battery condition meter.

This should connect between Pins B and F (white and green on the diagram). White is connected via the ignition switch to battery positive and green is always connected via the wiring to the battery negative.

9 Controls

The mating connector supplied is suitable only for the correct size of wire. Acceptable wire sizes are:

- 7 **stranded** 0.22-0.25mm²
- 24 AWG (7/32 AWG)

It is an Insulation Displacement Connector (IDC):

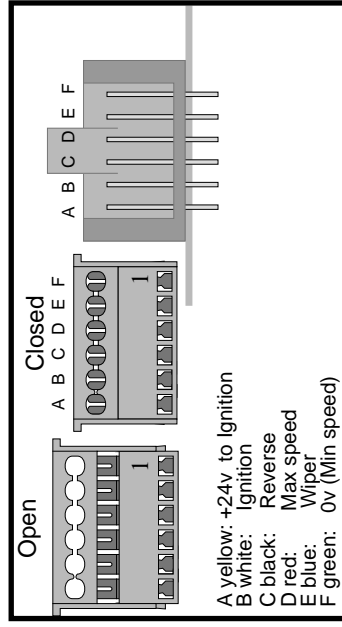

- A yellow: +24v to Ignition
- B white: Ignition
- C black: Reverse
- D red: Max speed
- E blue: Wiper
- F green: 0v (Min speed)

Do not strip the insulation from the wires, simply push them into the top part of the open connector, from the front (visible in the diagram) and squeeze it closed in a vice or with suitable parallel action pliers. As you do so, the tines of the contacts bite through the insulation to make contact with the conductors.

Wire which is too thin will not make good contact.
Wire which is too thick will damage the tines which may short to each other

You can re-open a closed connector by gently moving the tabs at the sides of the top cover outward to disengage the latches while lifting the cover slightly, one side at a time.

Pro-120 controller instructions

Pro-120 controller instructions

9.01 Speed pot

We advise a 10K linear pot, although you can use any value from 4K7 to 20K.

The gain adjustment on the controller alters the amount of rotation required before full speed is reached: this allows various input devices to be used.

The simplest speed control is an ordinary rotary pot: this won't give any 'dead man' control as the pot won't return to zero when it is released. 4QD can supply a spring return to zero hand control or a plunger operated pot (linear position sensor), suitable for incorporating into a foot pedal.

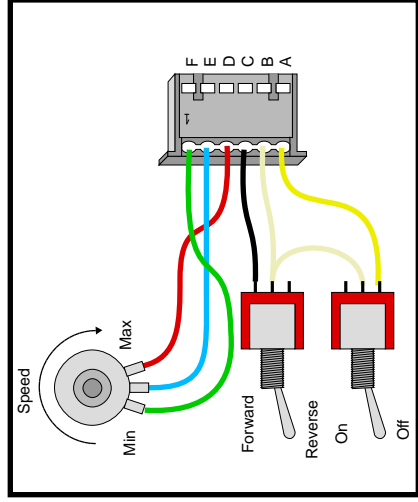

9.02 Use as voltage follower

Instead of a pot, the input may be fed from a variable voltage. 0v (common) to pin F, signal input (+ve) to pin E. A resistor (10k) should be connected from pin D to pin F to over-ride the internal pot fault detector circuit. Zero speed will be for zero voltage input and full speed voltage may be adjusted (by the pre-set) to be from 3v to above 20v.

9.03 Ignition (On/Off) switch

Circuitry in the controller switches it off (zero current consumption) unless pins A and B of the connector are joined. Therefore a switch **must** be fitted.

There are three ways of factory wiring the ignition: the following notes apply to the standard controller, not to the RW version.

Do not permanently link these pins. For correct operation, the ignition switch must be turned on (or the hand control box plugged in) *after* power has

been applied to the controller. If the ignition switch is turned on before power is applied then the ignition relay may not pull in properly as its operation relies on the Pro's internal capacitor charging through a bleed resistor *before* the ignition switch is closed.

Beware of opening the switch when the motor is running: the motor will brake to a halt more or less quickly, depending on the deceleration ramp setting.

With the ignition off, or even with the battery disconnected, the relays short out the motor so free-wheeling is not possible. To free-wheel properly the motor should be disconnected.

The Pro controller has special circuitry so that, if the ignition is switched off at full speed, the motor will be braked to a stop (under control of the deceleration ramp) and only when it has stopped will the ignition relay switch off. For this to work properly it is important that the 'Gain' control is not turned up too far - see section 11.01.

9.04 High Pedal lock-out

This feature switches off the ignition if this is activated with the speed pot other than at low speed to guard against the vehicle taking off because the ignition is activated with the throttle depressed.

In some applications this feature may be undesirable. e.g. with a Joystick Interface when the system will not power up unless the stick is central at switch on - this can cause confusion!. It can be disengaged by simply removing the header marked HPLO on the diagram 'features' - page 4.

9.05 Battery Discharge Protection

this can be used to protect the battery from damage that could be done by over-discharging it. To do this, the voltage at the controllers battery terminals is monitored and the performance is reduced as this voltage falls.

It is not fitted as standard to 12v controllers. The standard 24v controllers have the level set to a low voltage (about 15v) so it is effectively disabled. To enable it, fit the 12K resistor R_{byp} shown in the 'Connections' diagram (page 7). For variable cutback, you could fit a variable resistor. Or you could use a switch to enable/disable the feature. The level at which it works is controlled by the value of the external resistor.

The controller cannot know the difference between a flat battery and losses caused by very high battery current in wiring that is too thin, so in some applications it may have undesired effects. It can be disabled completely by linking out the pinstrip marked UVP on the features diagram. Spare 'jumpers links' are available from 4QD (JLK-001).

9.06 Reversing switch

Reversing switch connections are shown in the diagram (facing). Reversing is 'dual ramp' which means that, if the vehicle is reversed at speed, it automatically slows down under control of the deceleration ramp then, at zero speed, reverses and speeds up under control of the acceleration ramp.

Whenever the vehicle is in reverse, a speed reduction circuit operates, so that (if the gain adjustment has been set up sensibly) full reverse speed is half of full forward speed.

9.07 Half Speed Reversing

As supplied, reverse speed is half of forward speed. If reverse speed reduction is not required it can be disabled by moving the 'jumper' on the pinstrip shown in the diagram on page 4.

9.08 Dual Ramp Reversing

It is possible to disable the 'dual ramp' when reversing becomes 'pre-select' so that, if the reverse switch is operated at speed, nothing will happen until the demand speed is reduced to zero. Reversing will now occur when the demand speed is turned up again. In this mode a push switch can be used for reversing: push the switch as you move the speed control from zero to temporarily engage reverse and release it when the vehicle is moving. Then, when the speed control is again reduced to zero, the controller will drop back into forward automatically.

To disengage dual ramp, remove the header indicated on page 4.

10 Braking

the demand speed returns to zero, power is removed.

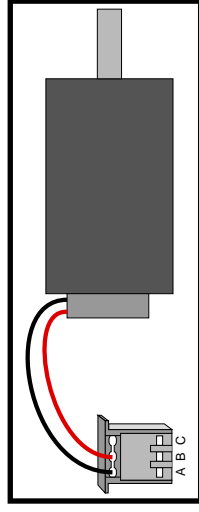

Parking brake drive is via the 3 pin connector, shown on the diagram 'Features'. This should be wired as in the first diagram.

The 3rd pin is battery negative so you can use a 3 position switch to give Release—Brake—Normal (brake override facilities), as shown in the diagram below.

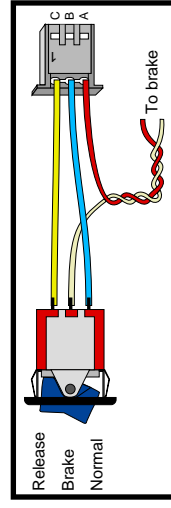

The brake driver will give 1 amp: if more current is drawn the controller will shut down.

Regenerative motor braking is integral to the Pro series controllers, but it can be disabled (see section 17). When the demand speed is reduced below the actual motor speed, the controller starts braking, returning as much of the braking energy as possible back into the battery. The rate at which the braking acts is adjusted by means of the deceleration adjustment.

For maximum energy recovery, use gentle braking. Turning the speed control to zero for maximum braking, shorts out the motor via the relays so there is then no energy recovery.

Regenerative braking does not work well at slow speeds, simply because it relies on the motor turning to provide braking energy. Therefore, if the motor is only turning slowly it cannot give a lot of braking, so a vehicle may creep if parked on a hill. To stop this creeping you can get motors fitted with an electro-magnetically operated **parking brake**.

Parking Brake

When power is applied to this, the brake is released and when power is removed the brake is applied by a spring. The Pro series controllers have a circuit to drive such a brake: power is applied to the solenoid as demand speed is increased above zero and when