

10 Specifications

Battery Voltage

16V to 48V nominal (self-adjusting)
55v
Maximum allowable (at power-up)

Typical Motor Current (Boxed controller. Board version will depend on mounting)

10 Seconds
5 Minutes
Continuous

120A
80A
60A

Power Terminals

Battery
Motor
Double 9.5mm fast-on blades.
9.5mm and 6.3mm fast-on blades.

Control Inputs

Throttle
Ignition
Reverse
10k Linear Pot. Other values can be used see section 5.3
Single Pole Switch.
Single Pole Switch.

Display

2-Digit, 7-Segment.

Programmer

3 buttons, integrated with display (may be removed)

Primary Adjustments ranges

Maximum Forward Speed
Maximum Reverse Speed
Forwards Acceleration Ramp Time
Reverse Acceleration Ramp Time
Forwards Deceleration Ramp Time
Reverse Deceleration Ramp Time

10% to 100%
10% to 100%
100ms to 1 minute
100ms to 1 minute
100ms to 1 minute
100ms to 1 minute

Fault Detection

Main Relay Check
Full MOSFET Integrity Check
High Pedal Lockout.
Online MOSFET Check.
High or Low Battery Voltage Check
Motor Current/Time Check
Throttle Fault Check
Heatsink Temperature Check

At startup.
At startup.
At startup.
100 times per second.
100 times per second.
100 times per second.
100 times per second.

Protective Mechanisms

Reverse Polarity Protection
Motor Current Limiting
Over Voltage Limiting
Under Voltage Limiting

-60V Max
150A to 60A, time profiled
60V
8V

Weight

Unboxed
Boxed
320g
630g



"We're in Control"



Office
30 Reach Road
Burwell
Cambridgeshire, CB25 0AH
Fax: 01638 744 080
http://www.4QD.co.uk



Stores
Unit 6A
Heath Road Industrial Estate
Burwell
Cambridgeshire, CB25 0AP
Email to: esupport@4QD.co.uk

Instruction Manual

Pro-150 Digital Motor Controller Mark 2

Software version 2.0

1 Introduction

The PRO 150 (PROgrammable 150 amp controller) is the first of a new range of 4QD motor controllers to benefit from digital technology.

The PRO 150 is a digital, four-quadrant motor controller for battery operation of permanent magnet DC motors. 4 Quadrant means that it controls speed and direction, drive and braking.

The standard controller is suitable for 24v to 36v batteries (14v through 42v operation). The 48v version is suitable for battery voltages between 16V and 48V.

The controller will not operate from 12v.

The battery voltage is shown, during normal running, on the display (if fitted).

The Pro-150 can deliver a motor current of up to 150A for short periods and up to 60A continuously. The Pro-150 is digital: it uses computer technology. This gives two advantages:

- 1 controllers with the identical programming will behave identically and reproducibly.
- 2 The controller is 'intelligent' and checks itself and its environment for faults: if it finds a fault, it

will not operate. Moreover, though the display module, it gives an indication of the nature of the fault found. No fault detection system can detect every possibly fault but, in practise, the controller should shut down safely in the presence of most faults which are likely to occur.

Provided the display is fitted, an indication of the fault found will be displayed: this makes fault finding much simpler and means that you are unlikely to have to return working controllers to the factory for checking.

When a display is not fitted, a sounder is present which will give a coded series of pulses to indicate the fault found. This can be particularly useful in, for instance, diagnosing a problem over a telephone

The Pro-150 is probably the easiest controller to program that exists.

2 Contents

Section	Page
1 Introduction	1
2 Contents	2
3 Safety	3
4 Dimensions and Mounting	4
4.1 Internal features, dimensions and mounting of board version	5
4.2 Mounting: display	6
5 Wiring	7
5.1 Simple wiring diagram	7
5.2 Motor, Battery and power connections	8
5.3 Control wiring	9
Input mode	10
Throttle Pot	10
Voltage following	10
Reverse switch	10
5.4 Auxiliary connector	11
5.5 Parking Brake	11
6 Operation	12
7 Altering the Performance	13
7.1 General	13
7.2 Programmable parameters	14
7.3 Programmer and display connection	14
7.4 Altering a parameter	15
Programming mode	15
Restore factory defaults	15
Software Issue Number	15
7.5 Programmable parameters in detail	16
8 Service and Fault finding	19
8.1 Detected Faults	19
8.2 Fault Numbers and codes	20
8.3 Fault sound codes	22
8.4 Other faults	22
8.5 Fuses	22
9 Service	23
Returning a controller	23
Serial number	23
10 Specifications	24

Fuse tracks can be repaired by anyone capable of soldering so if you need help - contact us (preferably by email) before returning the controller, or a handling charge will be made.

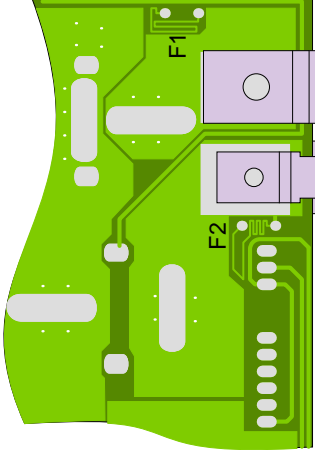

Do not use a strand thicker than 0.2mm diameter as this could allow other tracks to get damaged in the event of a fault.

9 Service

Returning controllers

First, make sure you have used the fault finding procedure (Section 8). If this is finding a fault, make sure the fault is in the controller and not in your batteries, motors or wiring.

Since working controllers have nothing to fix under guarantee, a charge is made for testing and handling so you are advised to contact us (preferably by email) before returning!

Serial number

Controllers are serial numbered with a 4 digit number, written on the circuit board near the sounder. The controller in the diagram on page 5 is numbered 1234.

Should you need to contact the factory about your controller please quote

- 1 Serial number
- 2 Software issue number (see page 15).
- 3 Details of the faults the controller has reported.
- 4 Details of any tests you have made to locate any fault.

8.3 Fault sound codes

The Pro-150 is fitted with a sounder which emits a pattern of sounds to indicate there is a fault and where this may be. It is particularly useful for remote diagnosis, by telephone, to the vehicle's manufacturer.

The sound code is the number of the code, as a 4 bit binary sound with the least significant digit first.

The list (right) show the beep pattern corresponding with each possible fault code. "—" denotes a long tone and "." a short one.

Note that not all possible fault codes have been assigned!

HL	Continuous tone
Pt	Continuous tone
CL	— — — — — — — — — —
01	— • • • •
02	• — • • •
03	— — • • •
04	• • — • •
05	— • — • •
06	• — — • •
07	— — — • •
08	• • • • —
09	— • • • —
10	0A • — • —
11	0B — — • —
12	0C • • — —
13	0D — • — —
14	0E • — — —
15	0F — — — —

3 Safety

Electric motors and batteries are dangerous. Any motor controller can only operate properly in a properly designed and functioning environment.

The Pro-150 can deliver short-term currents in excess of 150 amps. Batteries of the sort commonly used can deliver a huge amount more current: faulty wiring or components can therefore cause the batteries, the motor and their wiring to be a potential fire risk.

A digital controller performs checks on its wiring as it is switched on, and also does certain checks 'on the fly' during operation. These checks should catch most faults (inside the controller, as well as outside) but conditions of operation, programming and use are outside our control and 4QD can accept no liability for the results of any fault.

Suggestions for wiring etc are given in good faith and will suit most customers. 4QD can however accept no liability for the design of your particular machine: it is up to the machine manufacturer to make sure that the machine is safe under any and all fault conditions.

Circuit breaker

Faults in the battery or motor wiring pose a fire risk, as well as introducing the possibility of uncontrolled operation. You should make sure your batteries have adequate circuit breakers to disconnect them in the event of such fault, or in the event of unforeseen circumstances where the power must be disconnected.

Mechanical braking

In a controller with regenerative braking, mechanical brakes are hardly used. However, it is the battery that is doing the actual braking, not the controller. Faults in the battery or any of the power wiring can therefore render regenerative braking inoperative.

Mechanical braking should then be fitted as a safety precaution.

Mounting

The controller must be mounted so that water and dirt cannot contaminate it. **The metal base plate must not be modified** as this will produce metal swarf. **Such contamination is likely to compromise the controller's safety features and can make it behave in an unsafe manner or even destroy it.**

Such damage caused by contamination will not be repaired under the guarantee.

If water or other contamination does enter the controller you must disconnect the battery immediately and clean or thoroughly dry out the controller before re-connecting the battery.

The unboxed controller has no protection against contamination, so should not be used in environments where this is a possibility.

Metal swarf is the most dangerous kind of contamination, therefore never cut drill file or work metal in any way near to the controller or the motor unless properly sealed. In particular, never modify the base plate while it is attached to the controller!

The boxed controller, if properly mounted, has reasonable protection against rain etc.

The unboxed controller (or without its cover) and the display both have full battery voltage present on them: take great care that no conducting object or contamination touches them while the battery is connected. This is particularly likely if you are accessing them, for instance to alter the performance.

Handling

The capacitors in the Pro-150 can retain charge for a long while after the battery is disconnected so immediately after disconnecting the batteries turn on the ignition for a few seconds to discharge them.

8.4 Other faults

Internal Controller Faults

Internal controller faults are due to malfunctions within the controller itself, not the wiring and hardware it is connected to.

If an internal fault is suspected, make absolutely sure that there is no other possible cause.

Internal faults may result from contamination, by water or swarf for example. If the controller is contaminated with swarf, thoroughly blow it out. If the problem is water, dry it out and, if necessary, clean it and carefully try it out.

Water in itself does no damage but, if the battery is connected, electrolytic corrosion will occur. This can well be fatal to the controller! If there is corrosion, it is quite safe to use clean water and a mild detergent to carefully clean the board. Make sure it is properly dry again before re-testing it!

If there is definitely a persistent internal fault, consider returning the controller to 4QD.

8.5 Fuses

Two fuse tracks are present in the connections to the 6 pin connector:

F1: in the earth line to pin F. This also disconnects the earth to pin A of the brake connector.

F2: in the ignition feed (pin A) and power to the parking brake.

These fuses are present to restrict damage in the event of a wiring fault to the Control connector (C) or Brake connector (B). The two fuse tracks are indicated in the drawing (right): they are the long thin tracks F1 and F2.

If a fuse track gets blown, a self-resetting fuse (FSR-090) may be fitted in the holes provided.

Alternatively a single copper strand from a 7/02 cable may be used, soldered between the holes provided, although this is not guaranteed to restrict damage if the fault re-occurs.

4 Dimensions and Mounting

The dimensions of the controller's base plate are shown below. It has two M5 tapped screw holes for mounting: ideally it should be in thermal contact with the machine's chassis which will then act as additional heatsinking.

The controller may be mounted in any orientation. However you should consider whether it is likely to be subject to dust, dirt, oil or water during use and mount it appropriately.

The best orientation is vertically with connections at the bottom: this way is water splashes get onto leads etc. they will simply run downwards away from the controller. If water does splash onto the controller, it will run down the heatsink and away harmlessly. Otherwise mount with the heatsink at the bottom so water cannot get onto the circuit board.

Allow plenty of space to install the controller and all connecting wires, and mount so that the mounting screws can be easily accessed.

Heat Sinking

During operation, depending on motor current, the aluminium base plate controller can get hot. For best sustained performance, mounting to an external heatsink; something good at conducting heat with a large surface area exposed to the air. This may be the aluminium chassis of a vehicle, an aluminium mounting plate, or any other good heatsink.

Over voltage detected at switch on. (Power-up)
This fault is reported if battery voltage at switch on is over 55 volts.

04

Cannot discharge main capacitors at switch on.
There is likely to be a short in the motor wiring to battery positive.

Check also that you have not connected the battery positive connection to a motor terminal.

Switch off, disconnect the M+ and M- connections at the controller. Switch on again. If the fault is not now reported - your motor wiring is faulty!

Otherwise, it could be an internal controller fault.

05

Cannot pre-charge the main capacitors at power-up.
There is likely to be a short in the motor wiring to battery negative. If your battery negative is connected to chassis, check for shorts in motor or wiring to chassis.

Switch off, disconnect the M+ and M- connections at the controller. Switch on again. If the fault is not now reported - your motor wiring is faulty!

Otherwise, it could be an internal controller fault.

06

Bridge pulldown (PWM) failed (Power-up)
Likely to be an internal controller fault

07

Bridge pull up (PWM) failed (Power-up)
Likely to be an internal controller fault

08 Overheat!

The thermal sensor has detected over-temperature. This happens if the internal heatsink block temperature rises above about 90°C.

Switch off and allow the controller to cool down!

09

Over voltage detected during operation.
During regen braking, power is fed back to the battery: it is the batteries that do the braking - **not the**

controller! This fault is occurs if the battery voltage, during operation, rises too high. This is usually caused by a dud battery (that cannot accept braking energy) or a bad battery connection.

10

The parking brake is demanding excessive current (over 1 amp).

This fault will normally occur as the throttle is operated. The controller will not start up.

Remove the parking brake from the B connector and turn the ignition off and then on.

If the fault no longer occurs, there is a problem (usually a short circuit in the wiring) with the parking brake.

11

Inhibit input is active (low)

See section 5.4 for inhibit input.

The inhibit input is usually used with a battery charger to prevent the machine starting up with the charger plugged in.

Switch off: unplug the charger (or whatever else is using the inhibit input) and switch on again.

12

Bridge unresponsive

The microcontroller continuously checks that MOSFETs are working properly. If this fault occurs it probably means the micro has detected an internal fault.

To make sure, switch the controller off, disconnect both motor wires and switch on. If the fault still occurs there is an internal controller fault.

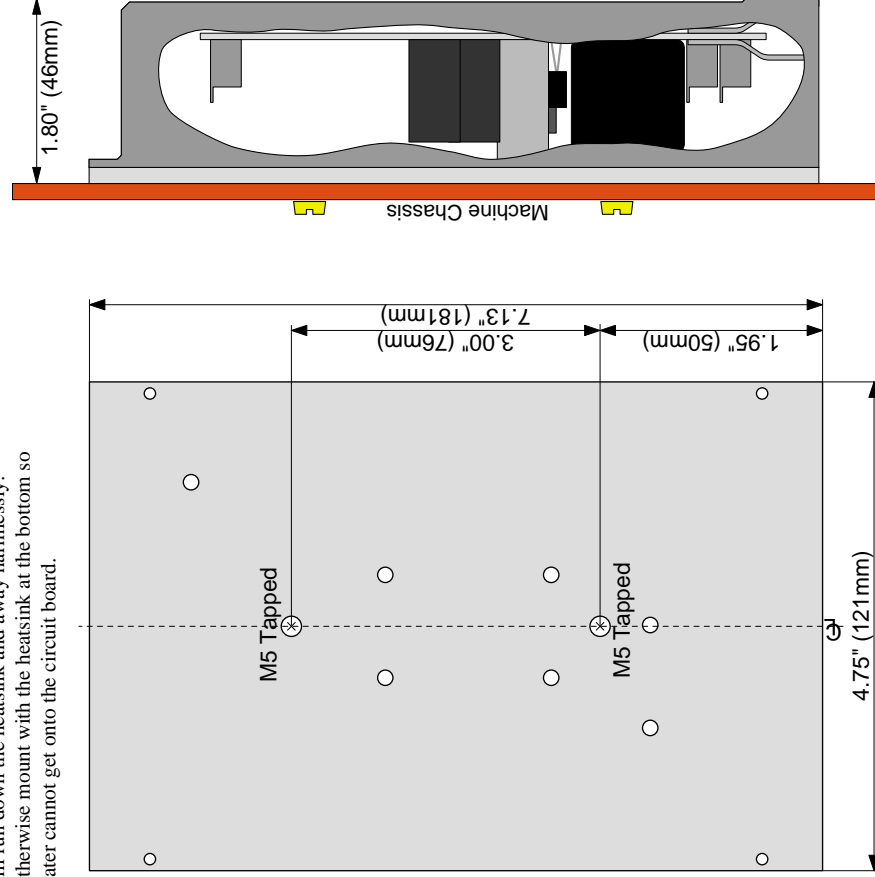

overcharged.

Pt

This indicates a Pot or wiring fault or blown fuse track (F1) such that the voltage on the top of the pot is high (above 4.7v) or low (below 2.5v). So check that F1 (page 23) has not been blown by a wiring fault.

It could also be a high resistance pot, or a broken wire or a short to the pot. The controller will behave as if the throttle is at zero while the fault persists.

The on-board sounder emits a continuous beep

-beep-beep-beep tone. The controller will operate normally again as soon as the fault is cleared.

PO

Pot over-voltage has occurred. Pot maximum speed input acceptable voltage (on pot wiper) is set up in parameters 12 and 13 (section 7) and PO occurs if the voltage exceeds this level. Usually caused by a broken earth wire to the pot. Will also be given if pot wiper is open-circuit or too high impedance.

PU

Pot under-voltage has occurred. The pot voltage has gone below the value set up for full reverse speed.

Permanent Faults

These all cause the controller to trip out. To reset, the ignition must be switched off then on again.

01

Ignition_off (Power-up)

This occurs if the voltage on the ignition line falls below about 16v. Possible causes include a dud battery, bad connections in the battery wiring and bad connections on the ignition switch.

Check also that you have not connected the battery positive connection to a motor terminal.

02

Battery voltage too low. (Power-up)

Not currently used (issue 1.3 software). Feature to be implemented.

03

Transient faults.

These faults do not cause a trip condition. When the fault is present, the controller will reduce speed, so the motor will decelerate to a stop if the fault remains.

As soon as the fault is removed, the controller will resume normal operation so will accelerate to the set speed.

CL

The controller has limited the motor current. This is because the load on the motor (therefore the controller) is excessive. This is not in itself a problem for the controller and is included mainly as user feedback. However, depending on the setting of the current limit parameter, if such loading is sustained for too long the controller may get hot and switch itself off.

The on-board sounder emits a continuous series of beeps.

HL

This occurs during power up tests if the throttle pot is not at zero. It will also occur if the pot wiper is open-circuit. HL will vanish when the problem is cleared.

The on-board sounder emits a continuous tone.

OP and UP

These indicate Over-voltage or Under-voltage Protection has occurred.

If the voltage at the controller's battery terminals becomes too high or too low while the motor is running, the over-voltage or under-voltage protection system adjusts the motor speed to keep the voltage within safe limits.

Under-voltage means that the motor current is excessive for the battery or wiring, so the voltage at the controller is dropping too low. If this happens often, it indicates the battery is bad or the wiring is too thin or faulty.

Over-voltage usually occurs during regeneration if the wiring is bad, or the battery is being excessively

4.1 Internal features, dimensions and mounting of board version

The diagram below shows the controller without the cover to identify the main features referred to in this manual.

The controller should be mounted by means of the two M4 tapped holes in the metal block heatsink, onto the chosen metal (preferably aluminium) plate.

Mounting: and Heat Sinking

The aluminium block of the unboxed controller may get hot and should be mounted in thermal contact with a suitable heatsink if sustained high current is required. For best results, heatsink compound should be used between block and heatsink

This plate will act as an additional heatsink.

This mounting is shown in the bottom diagram.

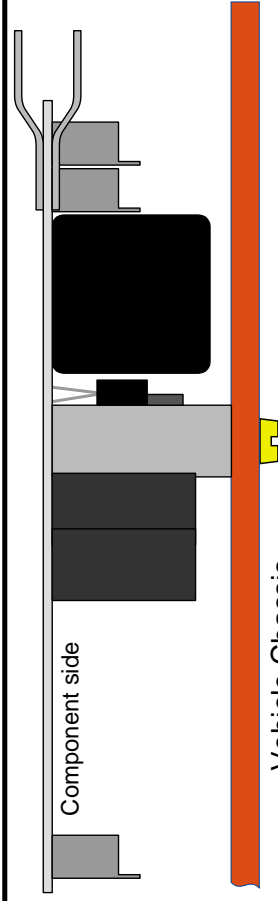
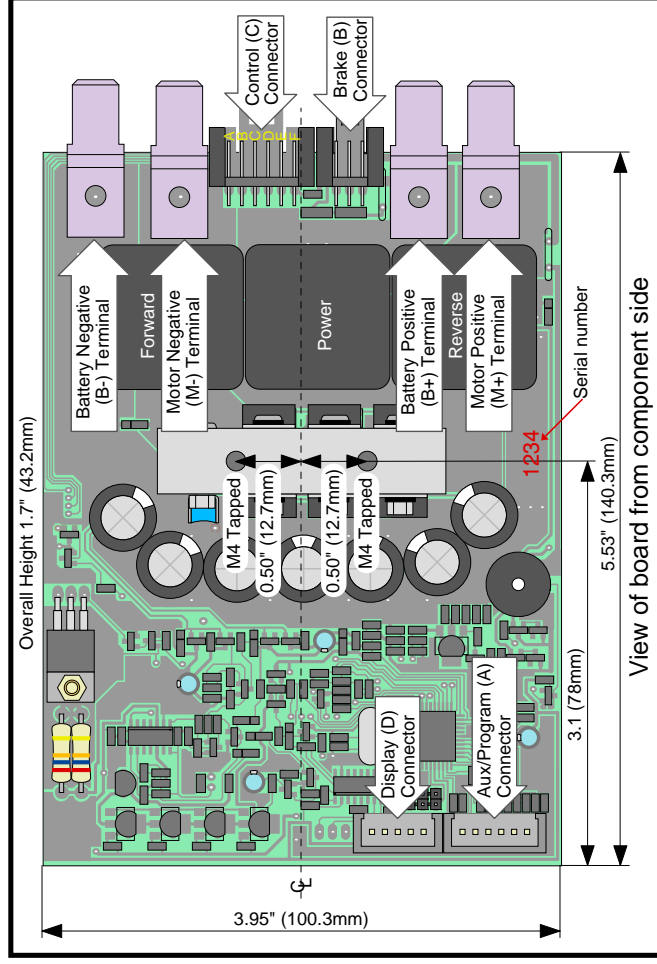

4.2 Display and Mounting

The display is supplied attached to the programmer, as shown below.

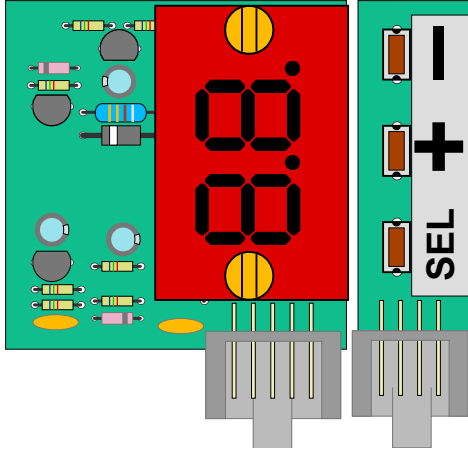

The display connects to the controller via a 4 way cable. See section 7.3 for connections.

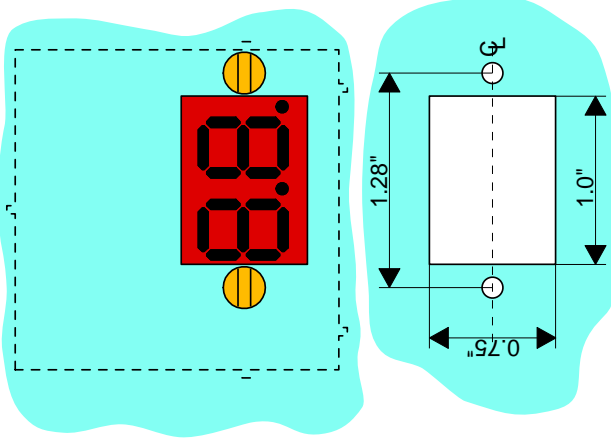

The display requires a rectangular cut-out in your panel, with two M3 clearance holes as shown above.

Supplied with the display is a red plastic bezel which should be sandwiched between the panel and the display as shown below.

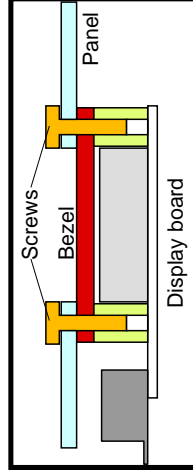

If you apply a thin bead of silicone rubber behind your panel before mounting the display you can easily make this completely water tight.

The Pro-150 has sophisticated self and environment testing so will find most faults that are likely. If such a fault is detected, the controller will shut down the and will sound a pattern of beeps and display an appropriate number to indicate the nature of the fault found. The fault number will flash on and off.

Most faults are caused by dud batteries, bad motors or bad wiring. The controller cannot know exactly what the problem is, but it will detect most such faults and will respond correctly to them by not working and by indicating a fault code.

If your controller doesn't work, you should check the following points before contacting 4QD for assistance.

Erratic fault display

If noise (probably from the motor wiring) gets into the display wiring the controller can show erratic faults. The controller may also have cause to abort updating the display, so erratic displays may occur. The display should rectify after a few seconds.

Controller is Completely Dead

If nothing is shown on the display and no pattern of beeps is sounded (i.e. the controller is completely dead, check

- 1 The battery positive and battery negative wires are connected correctly
- 2 that there is adequate battery voltage
- 3 the ignition switch is working and wired up properly.
- 4 the two on-board fuse tracks are not blown. See section 8.5.

If these are all correct, then there may be an internal controller fault.

Note: the display is powered from its own internal supply (derived from the batteries, through the controller) so that a dead display does not necessarily indicate a dead controller!

8 Service and Fault finding

8.1 Detected faults

Faults that the controller may detect are of two types:

Transient: will not damage the controller but mean it cannot do its job. The controller will show two letters while the fault persists and will resume operation if the fault clears.

Permanent: These are potentially damaging faults that cause the controller to shut down and show a number on the display.

The micro-computer should react properly to most likely faults and will give a high level of protection.

If the controller shuts down, note the number displayed (or the tone pattern sounded) as this will give a good indication of where the fault may lie. The controller will stay shut down and display this number until the ignition is turned off.

When the ignition is turned on after all faults are cleared, it will start up normally.

The **evan background** is the technical internal state detected by the micro and should be ignored if you do not understand it!

Parameter 12, 13 and 14: Pot / Input Learn

These all allow you to define how the speed pot and direction switch affect the performance.

Select the parameter. Turn the pot (the display will show 00-99 as you turn the pot, so finding the centre of a wig-wag is easy!), set the direction switch appropriately (if you are using one) and press **SEL**.

This indication of pot position allows you to measure what the pot is doing which could be useful in a factory making golf buggies, for setting up the speed pedal zero!

It is always better to adjust the throttle pot mechanism for correct 00-99 display on the controller than to match the controller to a badly adjusted throttle!

The controller is set as standard for 10K pot, will accept 5K to 15K. However, changing the pot value will affect slightly the speed range of the pot: these parameters allow you to fine tune this.

You can also define whether reverse is with the switch open or closed. Whether you want single ended or wig-wag. If you are using a voltage input, you can calibrate the controller to suit your input!

It is of course possible to tell the controller silly things: if you do this and try to program (by going to PG display), the controller will not accept the values.

If programming in wig-wag operation a 1k0 resistor should be fitted in the bottom of the pot - see note on page 10.

There may well be silly settings that the controller does accept - so if you change anything it is up to you to make sure it does what you want and is safe in your machine!

Parameter 12: Maximum speed forward.

Adjust the pot (the display will change to show where the pot is) and the direction switch (if you are using one) to the position and state you require as full

speed forward. Press **SEL**

Parameter 13: Zero speed.

Adjust pot to the zero speed position. Leave the Direction switch in forward. Press **SEL**

Parameter 14: Max reverse (or zero speed).

If you are using single ended mode, simply adjust the speed pot to zero, switch the direction switch to reverse and press **SEL**

The controller will use the pot as a zero to full speed input, with the switch for direction.

If you are using a wig-wag pot, adjust the pot to the position you require to be maximum reverse speed and press **SEL**

With a wig-wag pot, you will not, of course, be using a direction switch.

Programming end

When you have finished programming, you need to tell the controller "that's it - remember the new values".

Adjust the Parameter number above 14: the display will show PG.

If you have tried to re-program Pot Learn to values which do not make sense, the controller will not advance above 14!

Press **SEL**

The controller will remember the new values and go through its start up routing, so it may well show a fault such as HL (HPLO). Or if the pot is at zero, it will display the battery voltage and the controller is ready to go.

5 Wiring

5.1 Simple wiring diagram

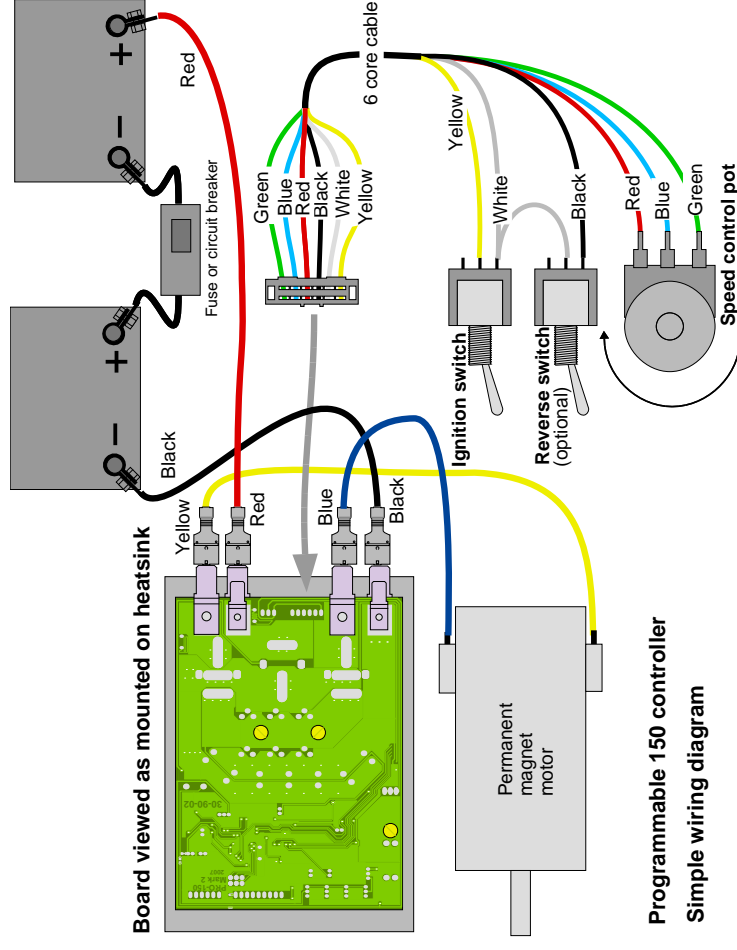

Programmable 150 controller Simple wiring diagram

The diagram shows the simplest wiring for the Pro-150. Wiring is covered in more detail in section 5.1.

Use of a reversing switch is optional: the controller can be programmed to accept a -wig-wag-(centre zero) pot. See section 7.5.

Display

Most installations will also include the display: this is not necessary to operation, but as it gives a read-out of battery fault and indicated the nature of any fault that may be detected in the system (see section 8.1), its use is strongly advised.

Red and green of the 4 way display connector on the controller board are effectively the same as ignition and pot - so it is possible to wire a control panel using these with only two extra wires for the signals.

BCM

4QD's BCM-524 or 748 can be used, connected between white and green wires. However the voltage here is fed via a diode so the BCM indication will be slightly lower than standard.

Fuse or Circuit breaker

Although this is not necessary to the controller's operation it will serve as a safety disconnect if required and it will also help protect against some possible faults - such as a short from motor to battery negative, which could destroy the controller if a fuse is not fitted. *Controllers destroyed thus are generally un-repairable. You have been warned!*

For most applications a breaker of 60 amps is adequate. A suitable circuit breaker is commonly available from most automobile audio sellers.

5.2 Motor, Battery and Power Connections

Power connections are to the 9.5mm tabs on the end of the board.

Note that the battery connections have one large (9.5mm) tab and one small (6.3mm): the small one is normally used to connect a battery charger or to feed ancillary equipment.

The controller's power contacts are designed for use with fast-on receptacles. (4QD can supply these pre- crimped to leads). Each motor contact can accept two 9.5mm receptacles (two feed two motors) and each battery contact can accept one 9.5mm and one 6.3mm receptacle.

Fully Insulated receptacles must be used to prevent shorts between contacts.

Cable size

Wire of at least 6mm² should be used for power connections. Undersized wire could overheat, resulting in excessive power loss, a risk of fire and should the insulation melt, the possibility of damage to the controller.

Crimps should be of good quality and properly crimped or they can overheat - in extreme cases poor crimps can irreparably damage the controller or even cause a fire risk.

Colours shown below are recommended. It is strongly advised that you use different colours for battery and motor to minimise the risk of connecting a battery wire to a motor terminal and thus destroying the controller!

Warning: Connecting a battery connection (particularly battery -ve) to any motor terminal may instantly destroy the controller.

Battery connections have one large (9.5mm) tab and one small (6.3mm).

Motor connections have two large (9.5mm) tabs.

Cable routing

It is very important to keep the B+ and B- wires as short as possible and to route them next to each other, possibly by twisting or tie-wrapping them together. Failure to do this could cause the main capacitors to overheat and will result in increased levels of interference being emitted.

Motor wires should also be kept as short as possible. Excessively long motor wires waste power and reduce performance, but do no damage. Cables should be routed next to metal chassis members where possible in order to minimise radiated electrical noise.

Motor Types

The PRO 150 is designed for use with permanent magnet DC motors, but can also be used with shunt wound motors.

It is usually sensible to use a motor with a similar or higher current rating to the controller. If the motor has too low a current rating, the controller will be able to deliver enough current to quickly overheat the motor when under load.

Parameter 01 and 02: Forward ramp times

These are the times for acceleration and deceleration in forward drive. The display is in seconds, 0.1 sec to 9.9 seconds so the resolution is 1 deciSeconds (tenth of a second).

Do not choose too fast (too small a number) an acceleration or deceleration for your machine. If you do, and it tips over when accelerating fast - don't blame the controller (or 4QD!).

Fast acceleration and deceleration may also shorten the operating life of the on-board relays.

Parameter 03: Max speed

This is the top speed. As you adjust this parameter the display will show 00 - 99. This is the percentage of available throttle electrical travel.

You can set this parameter in steps of 1% but low value settings make no sense and will not work! Generally, if your machine is too fast (so that you need to reduce the top speed electrically) your gear ratio is wrong.

Reducing top speed electrically causes the motor to take more current. This can overload the controller and the motor, so if your motor burns out (or the controller overheats) - do not blame the controller!

Parameter 04, 05 and 06: (reverse)

These are as parameters 01, 02 and 03, but for reverse rather than forward.

Some machines, e.g. golf buggies, are unsafe to drive in reverse, so different parameters are required.

Parameter 07: Dead band

This is most useful in joystick mode, where the centre of movement of the joystick may have a tendency to wander.

Default 5% of available throttle signal.

Parameter 08 and 09: Parking brake.

These control the parking brake: ignore if your motor does not have one fitted!

As the controller starts to apply power to the motor, it applies power to the parking brake you release it. Parameter 09 defines how much power is applied to the motor before the brake is released.

Too low a value will allow the machine to roll back on a hill start, too high a value and the motor will start with a jerk.

As the motor stops, there is a short delay before the brake power is removed (to allow the brake to re-engage). Parameter 08 defines this delay. Typical values will be 1/2 to 1 second.

Parameter 10: HPLO

If the controller's ignition is turned on with the pot high (not at zero) the controller would start up immediately. So a High Pot Lock Out (HPLO) function is present.

Parameter 10 sets the pot level which is considered high. The display will show 00-99 as the pot is turned from dead band level to full speed. Zero means the level is the same as the dead-band. 99 is full pot input. If the pot is above this level at switch on, HPLO will prevent operation until the pot is turned low.

So if you set this to 99: there is effectively no HPLO. If you set it to 10%, then any pot setting below 10% at switch on will be accepted: this will probably allow the machine to creep forward, which you may deem desirable but it's up to you to choose a safe value for your machine.

Generally choose a level of zero or only slightly more.

Default (most personalities) 2%.

Parameter 11: Reverse sounder

There is an on-board sounder which can be made to beep in reverse. This parameter turns the function on/off.

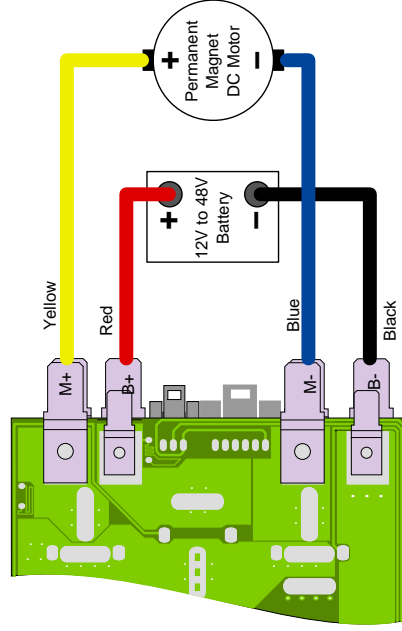

7.5 - Programmable parameters in detail

← Param no: →	Machine		Forward		Reverse		Dead	Pargy Brake	HPL0	Rev	Pot/Input Learn	
	No.	Machine	Accel	Decel	Max	Accel					Decel	Max
00	00	Default	4.0	2.0	99	2.0	05	01	01	99	00	14
01	01	Golf buggy, fast	2.0	1.0	99	2.0	05	01	01	99	00	12
02	02	Golf buggy, slow	4.0	2.0	99	4.0	05	01	01	99	00	13
03	03	Locomotive, fast	5.0	5.0	99	5.0	05	01	00	99	00	11
04	04	Locomotive, slow	9.9	9.9	99	9.9	05	01	00	99	00	10
05	05	Boat (fast)	0.5	0.5	99	0.5	05	01	01	99	00	09
06	06	As default	4.0	2.0	99	4.0	05	01	01	99	00	08
07	07	As default	4.0	2.0	99	4.0	05	01	01	99	00	07
08	08	As default	4.0	2.0	99	4.0	05	01	01	99	00	06
09	09	As default	4.0	2.0	99	4.0	05	01	01	99	00	05
		Maximum	9.9	9.9	99	9.9	10	50	01	99	00	04
		Minimum	0.1	0.1	99	0.1	01	01	01	99	00	03

Parameter 0.0: Personality

There are no fewer than 10 different 'Personalities'.

Initially most of these are set to the same values as the default (Personality 00.) but will be varied as user requirements are determined!

The table to the left lists the available personalities and their initial parameters. Parameter numbers are at the top (yellow background)

Changing the personality is the most that the average user will want to do, so in detail:

To change to a different personality:

- A** Turn off the ignition.
 - B** Press and hold down the **SEL** button on the programmer while you turn on the ignition.
- The display will show 00 (or the number of the current personality if not the default)
- C** Use + and - buttons to go to the number of the personality you want.

- D** Press **SEL**
- E** Use + button to increment the display (which is showing Parameter number) from 00. to 15. and beyond to **PG**.

- F** Press **SEL**

That's it! New personality. Controller ready for action. Use and enjoy! Wasn't it easy! Now you can tell your friends you are computer programmer!

If the motor has a higher current rating than the controller, the full torque output of the motor will not be available, but the controller will not be damaged since the motor current is automatically limited to a safe value for the controller.

Remember that motors are generally rated in terms of continuous current handling: for a typical motor short term current (1 minute rating) may be 3 or 4 times as much as continuous rating.

Use only good quality motors with brushgear and commutator in good conditions: badly work brushes and commutator can cause arcing (electrical noise) which can cause controller failure. To minimise this possibility it is desirable for the motor to be fitted with a suppression capacitor. If one is not present, a 10n 100V ceramic capacitor can be fitted between brush pairs as close to the motor as possible.

5.3 Control wiring

There are two control connectors, the positions of these are shown in the internal features diagram (page 5). Most uses will only connect to the main 6 way connector which is accessible without removing the controller's cover.

The Auxiliary connector allows some less common controls to be fitted.

The mating connector supplied for both is suitable only for the correct size of wire.

Acceptable wire sizes are:
7 stranded 0.22-0.25mm²
24 AWG (7/32 AWG)

It is an Insulation Displacement Connector (IDC):

Do not strip the insulation from the wires, simply push them into the top part of the open connector, from the front (visible in the diagram) and squeeze it closed in a vice or with suitable parallel action pliers. As you do so, the tines of the contacts bite

Battery Type

The PRO 150 is designed for use with rechargeable batteries of 18V to 48V nominal. The actual battery voltage can be between 13V and 60V. This allows plenty of room for droops or peaks in battery voltage under heavy motoring or braking.

Be aware that the controller feeds current back to the battery during braking, so if the battery is sensitive to over-charging (such as Li-ion) think about what will happen if regen braking is used when the battery is fully charged.

A fully charged lead-acid 48v battery can normally withstand the overcharging that can result when regen braking dumps energy into it but under these conditions the voltage may rise to 60v.

In nearly all cases, lead acid batteries will be used, and these are indeed a very good choice.

through the insulation to make contact with the conductors.

Wire which is too thick will damage the tines which may short to each other. Solid wire will quickly break with use.

You can re-open a closed connector by gently moving the tabs at the sides of the top cover outward to disengage the latches while lifting the cover slightly, one side at a time. Wire which is too thin will not make good contact.

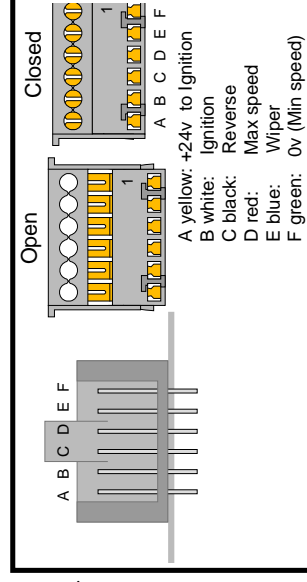

Input mode

The controller can work in two modes, either single ended (speed pot with separate switch for direction) or Wig-Wag where the pot centre is zero speed. Pot one way is forward and the other way is reverse.

Single ended is the default mode.

You can easily change to wig-wag either by switching to a different personality (if a suitable one exists) or by using the **input learn** feature, see section 7.5 for altering the programming.

Wig-Wag (aka Joystick) mode. A 10K resistor should be fitted in the bottom of the pot (pin F) as shown below when the controller is used in wig-wag mode. This is so that the voltage on the bottom end of the pot is above zero and full speed in this direction corresponds to a finite voltage. This voltage to go to zero, (outside the programmed pot voltage range) under fault conditions.

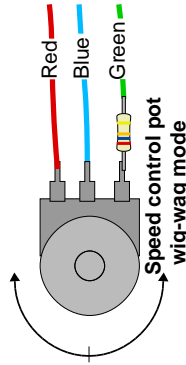

If this resistor is not fitted a fault such as a break in the top of the pot or a short wiper to battery - we will not be detected and may cause full speed operation.

Throttle Pot

The controller is optimised for a 10K pot, although any pot from 1K to 15K can be used. The pot can take many forms; a simple rotary pot, a spring return throttle lever, a twist grip, a plunger pot, a joystick, or any other resistance based throttle device.

It is important to choose the right kind of throttle device for the intended application. For example, on a ride-on vehicle, it is important that the throttle has a spring return, so that the vehicle cannot run away with no one at the controls, while on an electric boat, a friction joystick might be better.

4QD can supply all sorts of throttle devices as well as complete control boxes and panels, all listed on our [www site: www.4qd.co.uk](http://www.4qd.co.uk)

If pots above 15K or below 1K are used, the fault Pt will be displayed indicating the pot is out of range. See section on fault finding.

Voltage following

The Pro-150 can be used as a voltage follower. A 10K resistor must be fitted between pins D and F so pot fault is not triggered.

The pot wiper must not be open-circuit: if the source impedance is too high this will be registered as a PO fault (input is internally pulled up with 330K to 5v rail).

Zero voltage and maximum voltage can of course be programmed as required in the range 0 to 4.7v as can wig-wag operation in this range.

As supplied, with the default personality, zero speed is for 0v and full speed is about 4.7v. Any voltage above 4.7 will cause a fault **PO**

Reverse switch

The Reverse switch changes the motor direction depending on whether it is closed or open. Standard performance is

Switch open (or absent) the controller will be in Forward.

Switch closed, the controller will reverse.

Use of a switch is optional: in wig-wag mode both speed and direction are controlled by the speed pot.

The reversing switch is learned by the **input learn** feature so if you wish the controller to go in reverse (rather than forward) when the switch is open, this can easily be altered! See 7.5.

7.4 Altering a parameter

Plug in the controls you propose to use (see section 5.1), the programmer and the display (if not already in use).

Programmer and display connect as shown in the diagram opposite (leads are shown shortened for clarity). It does not matter if the programmer has been separated from the display.

The ignition must be **off** initially. Connect a battery or suitable power supply. The display will also be off. What happens now depends on which of the programmer buttons is depressed while you turn on the ignition. Release the button as soon as the display registers.

Programming mode

SEL The controller will enter programming mode

Restore Factory Defaults

+ Fd will be displayed for a few seconds. Releasing + while Fd is displayed will cause the factory default parameters to be restored. Holding + down will show fault 11 (Inhibit activated). Useful if you have been altering parameters and want to forget your alterations.

Software Issue

- The controller will display a number which is the software version number.

Entering Programming mode

1 Press and hold down the **SEL** button on the programmer while you turn on the ignition.

The controller will switch on in **programming mode**.

To indicate this the display shows **00** with the decimal point flashing slowly. You are now programming!

You are most likely to want to change parameter **00** (Personality number).

Any other parameters you alter will only affect the personality that is active when you change them.

If you do want to change the personality, skip step **2** and go to step **5**

2 Use the + and - buttons to change the number displayed to that of the parameter you want to alter. See table opposite for a list of changeable parameters.

3 Press **SEL** to tell the micro this is the number of the parameter you wish to alter: the display will change to show the present Value of this parameter.

4 Use the + and - button to increase or decrease the number on the display to the new value you wish to use. Each press will increment the number by one step.

Keep your finger on a button and the display will change automatically, speeding up as it goes. Remove your finger when you get near the required value, and use individual presses to get it exact.

5 Press **SEL** to accept the new value and return to Parameter Number mode.

If you wish to alter another parameter, use **SEL** again (step 2).

7 Once all parameters have been altered as you want, increment the parameter to **PG** (above parameter 14) and press **SEL**.

There will be a short pause as the new values are stored. Then the controller will go through its normal power-up routine (see section 6).

The new values you entered were accepted and stored in the personality number you used when you started changing them.

If you turn off the ignition at any time during programming, the changes will not be remembered: this is a way of cancelling your changes should you change your mind!

Remember you can always reset the controller to the factory default by turning on the ignition with + held down.

Repeat as required

7.2 Programmable parameters

The following parameters can be altered:

No.	Definition	Values	Comments
00.	Change Personality Number	00 - 10.	See page 16
01.	Forward Acceleration Ramp Time	0.1—9.9 Sec	Seconds, adjustable in deciSeconds,
02.	Forward Deceleration Ramp Time	0.1—9.9 Sec	Seconds, adjustable in deciSeconds,
03.	Max Forward Speed	00—99 %	in 1% increments
04.	Reverse Acceleration Ramp Time	0.1—9.9 Sec	Seconds, adjustable in deciSeconds
05.	Reverse Deceleration Ramp Time	0.1—9.9 Sec	Seconds, adjustable in deciSeconds
06.	Max Reverse Speed	00—99 %	in 1% increments
07.	Throttle Dead band	0-10 %	Default 5%
08.	Parking Brake Delay	0.1-9.9 Sec	Default 1 sec
09.	Brake threshold	0—10%	Default 1%
10.	High Pot Lockout	0—99%	Default 2%
11.	Reverse Beeper	Yes/No	
12.	Pot / direction max reverse	00-99	Measures pot
13.	Pot zero	00-99	Measures pot
14.	Pot / direction max forward	00-99	Measures pot
PG	Accept new programmed values		

7.3 Programmer and display connection

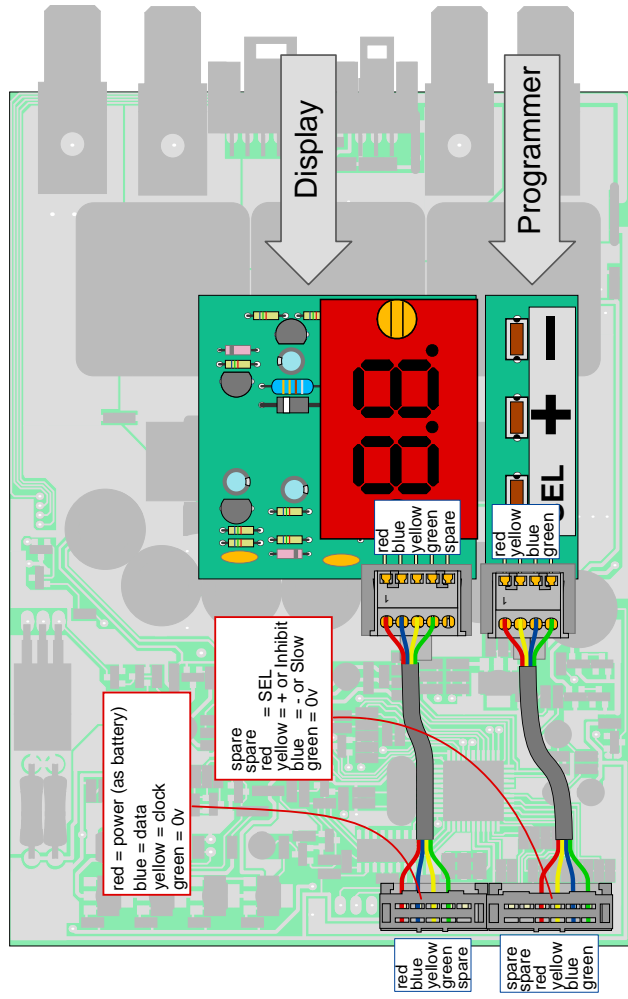

5.4 Auxiliary connector

The Auxiliary/Programming connector (A), inside the controller, can be used for additional controls when the programmer is not in use. Even if you are not using this it is best to unplug the programmer lead from the controller unless you are actually using it.

Connections are identified in the diagram right.

Slow / Fast

A fast /Slow switch can be fitted as shown. When this is closed (pin A connected to Pin B) the controller's top speed will be reduced to about half full speed.

Inhibit

An inhibit switch may be fitted (inhibited when pin C is shorted to pin A) ; when this is closed, the controller will not operate. Trip code 11 will be displayed. When the inhibit is removed, the controller's ignition must be switched off and on again to reset it.

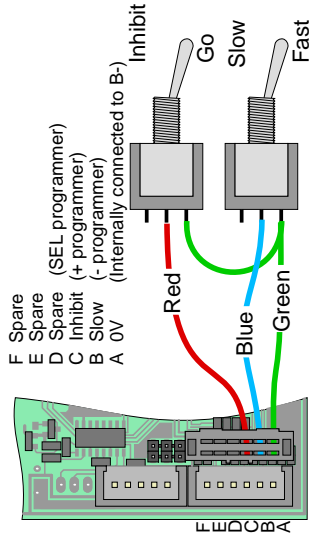

If Inhibit is activated during motion, the controller will ramp down to zero speed and stop. It may thus be used as an input for a motor overheat sensor.

This input may be used with a third connector in the charger socket so that the controller cannot start up when the charger is plugged in.

5.5 Parking Brake

Some motors are fitted with an electromagnetic brake to lock the motor shaft once it has stopped. This is commonly used on mobility vehicles as a parking brake. The brake is released by the controller applying the battery voltage to it when drive is engaged.

Such a brake can be connected to the B connector as

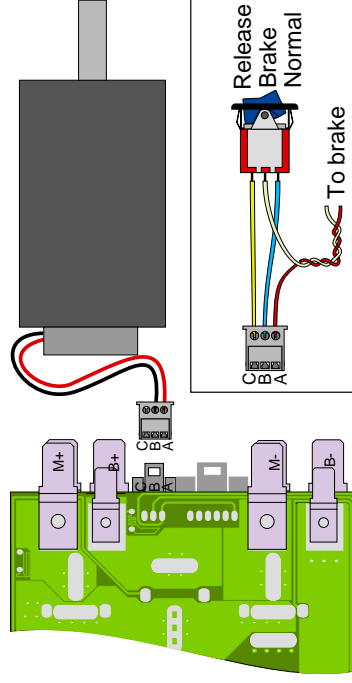

The controller does not detect an open-circuit parking brake so this may be left disconnected if a brake is not fitted.

A 3rd pin (C) is present: this is internally connected to battery -ve and may be used to wire a 3 position switch as show inset.

6 Operation

Switching On

When you turn on the ignition to start the controller up, it performs a number of system safety checks. During this period you may hear the three relays clicking and the display may show a sequence - such as C0, C1, C2, C3, C4, C5 - as it performs these checks. However, this checking is so fast you normally won't see it! If the display gets stuck on one of these, there may be a problem and the display will eventually show a fault number (see section 8.1) and the sounder will beep a fault code.

If all is well, the display will finally show a steady number which is a measurement of the battery voltage. The controller is now ready to work.

If there is a problem with any of these safety checks, the display will flash a fault number (or code), the beeper will sound a code and the controller will not operate.

Two most likely fault the controller may detect during power-up is:

Pot (or pot wiring) fault

If the controller detects a fault here, it will display **Pt**

High Pot Lock Out (HPLO)

If you do not have the speed pot at zero speed when you switch on, the controller will not operate until you turn the speed to zero.

If the controller detects the pot is not at zero speed, it will display **HL** until you turn the speed pot to zero and keep it at zero for a short period.

Then the controller will display the battery voltage.

Flashing number

Other faults may of course occur and be detected. In this case the number displayed will flash to indicate a fault has been found.

More information on these can be found in section 8.1.

Operation

Initially, you will probably want to check out the operation with the default 'personality'.

Once successful power-up has occurred, pot lockout has disengaged, move the throttle to control the speed. The further the throttle is moved, the higher the speed will be.

If a reversing switch is used, operate the reverse switch to choose the required motor direction.

Acceleration and deceleration rates are controlled give a smooth throttle response.

If the throttle is moved quickly, the speed changes smoothly at a rate depending on the ramp time settings. The default acceleration is 4 seconds to full forward speed, and 2 seconds to decelerate from full forward speed to zero.

Different ramp rates apply in reverse, and full reverse speed is normally half of full forward speed. You can easily alter any of these rates and speeds, see section 7.2.

Dual Ramp reversing

If the machine is operating at full speed and you change direction (probably by using the direction switch) the controller will

- 1 decelerate to zero speed, (controlled by the deceleration ramp rate)
- 2 pause for a fraction of a second
- 3 Accelerate (under control of the acceleration ramp rate) to full speed in the opposite direction

This is therefore called 'dual ramp reversing' and is the most useful performance in most applications.

Switching off

Turn the ignition switch off to shut the controller down.

You will usually do this after the motor has stopped. However, if the ignition switch is turned off while the motor is running, the display flashes 18 and the controller will reduce the motor speed smoothly down to zero before it shut itself down.

7 Altering the Performance

7.1 General

The Prog 150 is operated by a built-in 'micro-computer'. This Micro can be be-very easily instructed to alter the performance.

There are two features which the average user is most likely to wish alter.

Personality. The micro has several different 'personalities' built in, to give performance matched to, for instance, a golf buggy, or a miniature loco. It may easily be switched from one personality to another.

Input Learn:

the standard 'default' performance is optimised for a 10K pot with a switch for direction (as shown in the wiring on page 7). However, if you are using a different value pot, or wish to use a wig-way input, or some other combination, or wish to use a voltage input - the controller can be easily taught what control system you are using.

Programming method.

This is a brief introduction: full instructions are given in section 7.4

Programming is done via the 3 button programmer which is supplied attached to the display.

Programming is started by turning on the ignition with the **SEL** button depressed.

The display will indicate **00** to show it is in programming mode.

The number displayed now is the number of the parameter you wish to alter.

Be aware of the difference between the number of the parameter you are about to alter and the actual value of that parameter. When choosing a parameter number, the RH decimal point will flash indicating that you are not changing anything yet, but are simply choosing what to change.

Whether choosing a parameter to alter, or changing the value of that parameter, the + and - buttons will increment the number displayed.

Parameter number

When the right decimal point is flashing, the + and - buttons will alter the display to show the parameter numbers. There are 15 user-adjustable parameters, 00-14.

If the display is incremented above 15 it shows PG. Pressing **SEL** when PG is showing causes the microcomputer to remember the new values.

When you reach the number of the parameter you wish to alter, press **SEL** and the display will change to indicate the current value of that parameter. The +/- buttons will alter the display so you can select a new value.

Once the display shows the new value you want, press **SEL** again to accept this value and you will be returned to **Parameter number** mode so you can alter another parameter.

If you switch the ignition off during programming, all your changes will be forgotten. This is handy should you have second thoughts and decide to abort the changes.

Warning

After altering anything take care to check that you have altered what you expected: it may be best to chock the machine up so its wheels are free and it will not move, so you can check you did exactly what you wanted to.

Neither the controller nor 4QD can be responsible for you instructing it to do something which may not be safe in your machine! Or if you do not properly understand what you are doing!

Be aware that the values you chose for any parameter will only effect the current personality. So if you are using personality 03 (locomotive) and alter, for instance, the maximum reverse speed, you will not affect the reverse speed in any other personality.