

amequipment.com
Phone: (541) 327-1546
FAX: (541) 327-1548

210 series motor

210-1010

- 10Nm stall torque actuator motor, LH
- 12V reversible
- Water resistant
- Weighs 1.3 pounds

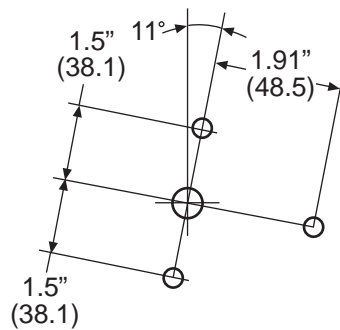
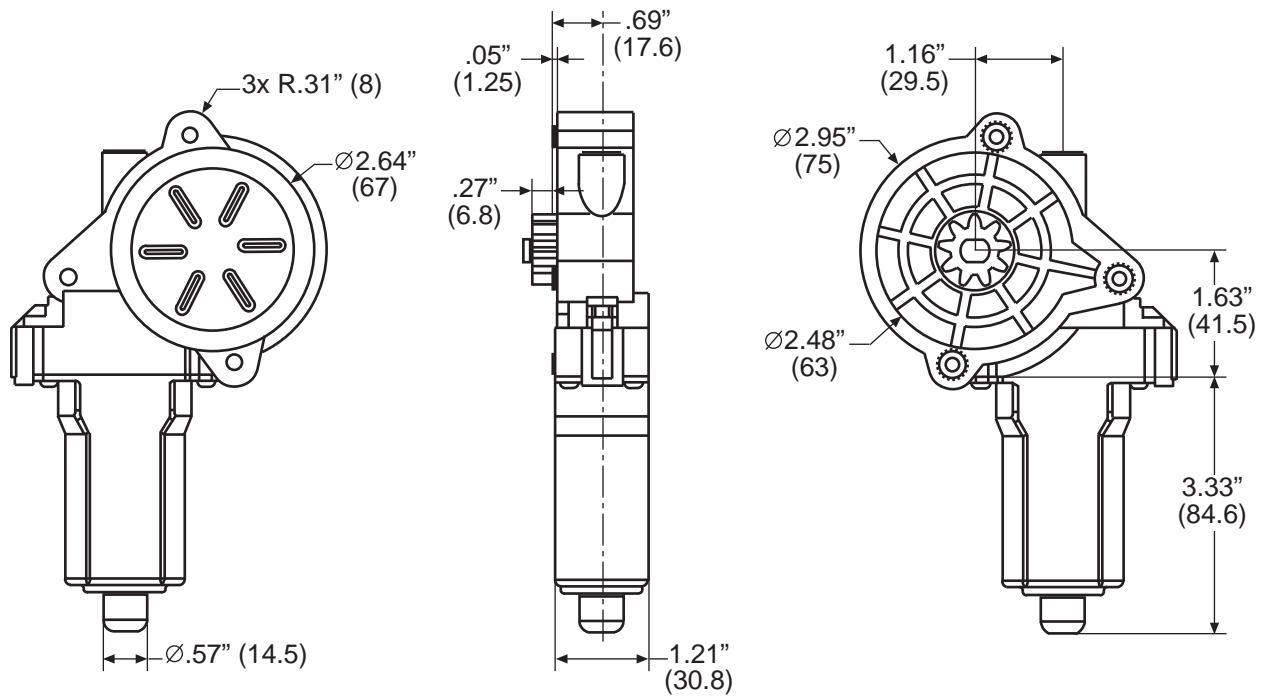
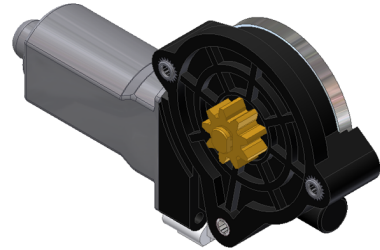

Mounting pattern

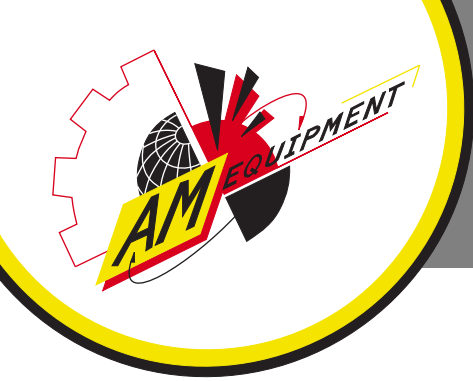

amequipment.com
 Phone: (541) 327-1546
 FAX: (541) 327-1548

210 series motor

210-1010

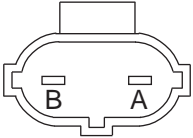

Mate terminal: 317-1044
 Wire seal: 317-1046
 Mate terminal housing: 317-1058
 Wire retainer: 317-1059

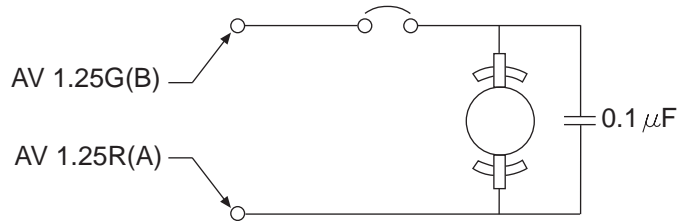

Counter-Clockwise Motor Shaft Rotation		
Data Point	Data Type	Value Range
No Load	Current (A)	3.5 - 2.9
	Speed (rpm)	108.0 - 88.5
Stall Load	Torque (Nm)	11.2 - 9.2
	Current (A)	26.9 - 22.0
Peak Power	Power (W)	29.1 - 23.8
	Torque (Nm)	6.1 - 4.9
Nominal (Peak Efficiency)	Power (W)	21.2 nominal
	Speed (rpm)	67.4 nominal
	Current (A)	8.8 nominal
	Torque (Nm)	3.1 nominal
Clockwise Motor Shaft Rotation		
Data Point	Data Type	Value Range
No Load	Current (A)	3.8 - 3.0
	Speed (rpm)	106.2 - 86.9
Stall Load	Torque (Nm)	11.0 - 9.0
	Current (A)	28.0 - 22.9
Peak Power	Power (W)	30.9 - 25.3
	Torque (Nm)	5.6 - 4.6
Nominal (Peak Efficiency)	Power (W)	24.2 nominal
	Speed (rpm)	70.1 nominal
	Current (A)	9.2 nominal
	Torque (Nm)	3.4 nominal

