

DIRECTION OF ROTATION

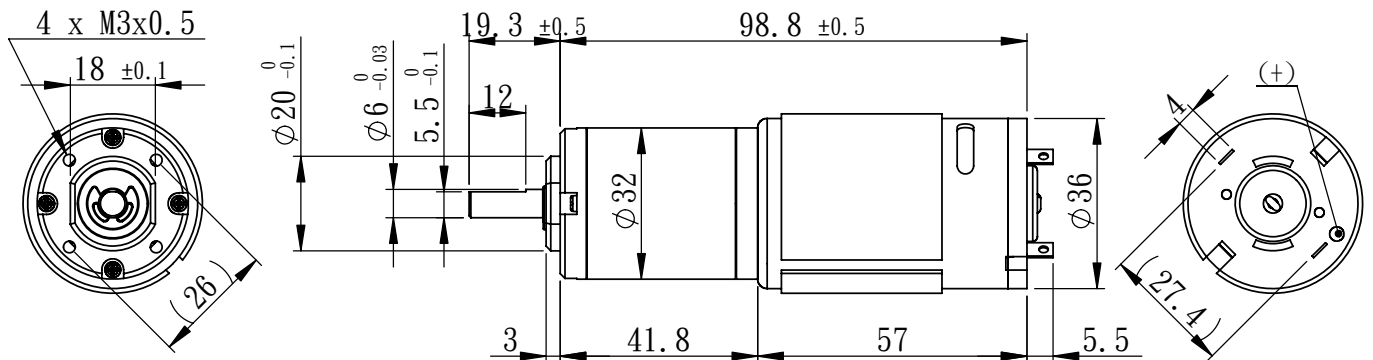

(unit:mm)

A. Operating Conditions:

1	Operating Voltage Range	6~12	V DC	4	Operating Temperature	-10~+60	°C
2	Rated Voltage	12	V DC	5	Storage Temperature	-30~+85	°C
3	Nominal Voltage	12	V DC	6	Rated Load	30	kgf-cm

B. Electrical Characteristics:

1	No-load Current	0.85	A (MAX.)	6	Stall Current	35	A (MAX.)
2	No-load Speed	37±3	rpm	7	Insulation Resistance(500V)	20	MΩ (MIN.)
3	Rated-load Current	5.0	A (MAX.)	8	Dielectric Strength	250	AC V
4	Rated-load Speed	31.5±3	rpm	9	Motor Brush Type	Carbon Brush	~
5	Stall Torque	250	kgf-cm(MIN.)	10	Output Power at Max.Eff.	25	Watts

C. Mechanical Characteristics:

1	Gear Type	Planetary	~	7	Output shaft Radial Load	3	kgf(MAX.)
2	Gear Ratio	1/264	~	8	Output shaft Run-out	0.05	mm(MAX.)
3	Gear Material	Mixed	~	9	Shaft End play	0.3	mm(MAX.)
4	Rated Tolerance Torque	15	kgf-cm(MAX.)	10	Bearing Type	Ball	~
5	Momentary Tolerance Torque	45	kgf-cm	11	Net Weight	340±20	grams
6	Output shaft Axial Load	2.5	kgf(MAX.)				