

**BNF**  
BASIC

# UMX™ AS3Xtra

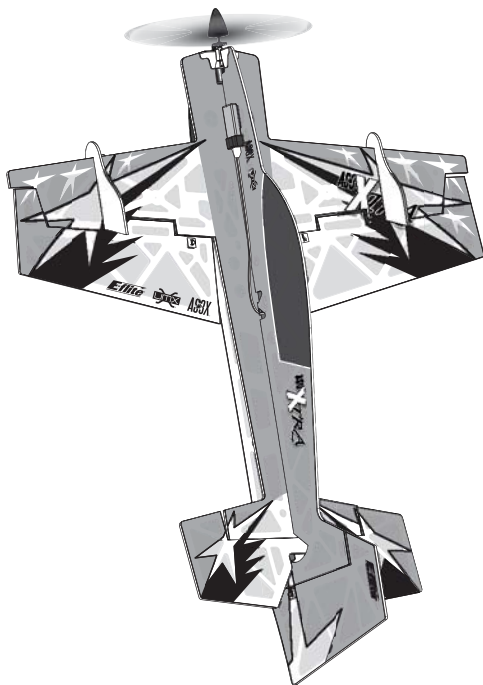

*Instruction Manual  
Bedienungsanleitung  
Manuel d'utilisation  
Manuale di Istruzioni*

**AS3X**®

**E-flite**®  
ADVANCING ELECTRIC FLIGHT

**NOTICE**

All instructions, warranties and other collateral documents are subject to change at the sole discretion of Horizon Hobby, Inc. For up-to-date product literature, visit [www.horizonhobby.com](http://www.horizonhobby.com) and click on the support tab for this product.

**Meaning of Special Language:**

The following terms are used throughout the product literature to indicate various levels of potential harm when operating this product:

**NOTICE:** Procedures, which if not properly followed, create a possibility of physical property damage AND little or no possibility of injury.

**CAUTION:** Procedures, which if not properly followed, create the probability of physical property damage AND a possibility of serious injury.

**WARNING:** Procedures, which if not properly followed, create the probability of property damage, collateral damage, and serious injury OR create a high probability of superficial injury.

 **WARNING:** Read the ENTIRE instruction manual to become familiar with the features of the product before operating. Failure to operate the product correctly can result in damage to the product, personal property and cause serious injury.

This is a sophisticated hobby product. It must be operated with caution and common sense and requires some basic mechanical ability. Failure to operate this product in a safe and responsible manner could result in injury or damage to the product or other property. This product is not intended for use by children without direct adult supervision. Do not use with incompatible components or alter this product in any way outside of the instructions provided by Horizon Hobby, Inc. This manual contains instructions for safety, operation and maintenance. It is essential to read and follow all the instructions and warnings in the manual, prior to assembly, setup or use, in order to operate correctly and avoid damage or serious injury.

**Age Recommendation: Not for children under 14 years. This is not a toy.**

## Safety Precautions and Warnings

- Always keep a safe distance in all directions around your model to avoid collisions or injury. This model is controlled by a radio signal subject to interference from many sources outside your control. Interference can cause momentary loss of control.
- Always operate your model in open spaces away from full-size vehicles, traffic and people.
- Always carefully follow the directions and warnings for this and any optional support equipment (chargers, rechargeable battery packs, etc.).
- Always keep all chemicals, small parts and anything electrical out of the reach of children.
- Always avoid water exposure to all equipment not specifically designed and protected for this purpose. Moisture causes damage to electronics.
- Never place any portion of the model in your mouth as it could cause serious injury or even death.
- Never operate your model with low transmitter batteries.
- Always keep aircraft in sight and under control.
- Always use fully charged batteries.
- Always keep the transmitter powered on while aircraft is powered.
- Always remove batteries before disassembly.
- Always keep moving parts clean.
- Always keep parts dry.
- Always let parts cool after use before touching.
- Always remove batteries after use.
- Always ensure failsafe is properly set before flying.
- Never operate aircraft with damaged wiring.
- Never touch moving parts.

The E-flite® UMX™ AS3Xtra takes Ultra Micro eXtreme to the next level. Constructed of laser-cut flat foam with carbon reinforcement and micro-thin film, this aircraft was specifically engineered to optimize super-low wing loading, strength and durability, plus AS3X® technology to provide outstanding 3D performance in tight flight spaces. Based on the ground-breaking original UMX Extra 300 3D, the addition of AS3X technology makes it possible to be even more successful whether it's performing the simplest loop or the latest extreme 3D moves.

Please be sure to read through this manual carefully so that you are equipped to successfully enjoy all the benefits this outstanding ultra micro model has to offer.

## Table of Contents

Preflight Checklist.....	4	Control Horn Settings.....	9
The Incredible AS3X® system		Dual Rates.....	9
Aerobatics Experience.....	4	Flying Tips and Repairs.....	10
Low Voltage Cutoff (LVC).....	4	Post Flight Checklist.....	10
Transmitter and Receiver Binding.....	5	Power Components Service.....	11
Alternate Flight Mode Programming.....	6	Troubleshooting Guide.....	12
ESC/Receiver Arming, Battery Installation and		Limited Warranty.....	13
Center of Gravity.....	7	Warranty and Service Information.....	15
Optional Side Force Generators (SFGs) Installation	8	Compliance Information for the European Union...	15
Control Direction Test.....	8	Replacement parts.....	58
Control Centering.....	9	Optional parts and Accessories.....	59
Trimming.....	9		

## Specifications

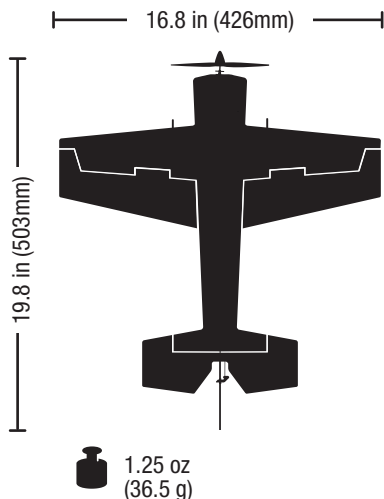

### Installed



**Motor:** Ultra Micro Brushed Motor  
8.5mm x 23mm (EFLU5152)



**Receiver :** DSM2/DSMX UM AS3X  
Receiver/Servos/ESC, UMX AS3Xtra  
(EFLU5164)



(2) 2.3-Gram Performance Linear Long  
Throw Servo (SPMSA2030L)

### Needed to Complete



**Battery:** 150mAh 1S 3.7V 25C/45C  
Li-Po, (EFLB1501S25 or EFLB1501S45)



**Battery Charger:**  
Celecra™ 4-Port 1S 3.7V 0.3A DC  
Li-Po Charger (EFLC1004)



**Recommended Transmitter:**  
Full range Spektrum™ DSM2®/DSMX®  
with dual-rates (DX4e and up)

## Preflight Checklist

✓	
	1. Charge flight battery.
	2. Install a fully charged flight battery in the aircraft
	3. Bind aircraft to transmitter.
	4. Make sure linkages move freely.
	5. Perform Control Direction Test with transmitter.

✓	
	6. Set dual rates
	7. Adjust center of gravity.
	8. Perform a radio system Range Check.
	9. Find a safe and open area.
	10. Plan flight for flying field conditions.

## The Incredible AS3X® system Aerobatics Experience

The Artificial Stability – 3 aXis (AS3X) system developed by Horizon Hobby product developers is an electronic advancement that virtually eliminates common barriers RC pilots fight on a regular basis. Its combination of multi-axis sensors and exclusive software reduces the correction workload normally required to combat turbulence, adjust for torque effects, p-factor and goes even further by stopping or significantly delaying tip-stalls. Beyond an increase in stability, the AS3X system provides enhanced agility you can use to perform aggressive maneuvers with a higher level of precision more easily.

Now the AS3X system has been expanded to an evolutionary level by providing multiple flight assistance options. For the UMX AS3Xtra, there are five pre-programmed flight modes to make complex maneuvers such as knife edge, harrier and hovering easier to accomplish. Change between AS3X modes at the flip of a switch to best suit the way you want to fly instantly. Not only will you feel as if your in total command of a much larger expertly tuned model, it delivers the kind of control confidence that will unlock maneuver capability that some pilots might take years to master.

To see what we mean, go to [www.E-fliteRC.com/AS3X](http://www.E-fliteRC.com/AS3X).

## Low Voltage Cutoff (LVC)

When a Li-Po battery is discharged below 3V per cell, it will not hold a charge. The aircraft's ESC protects the flight battery from over-discharge using Low Voltage Cutoff (LVC). Once the battery discharges to 3V per cell, the LVC will reduce the power to the motor in order to leave adequate power to the receiver and servos to land the aircraft.

When the motor power decreases, land the aircraft immediately and replace or recharge the flight battery.

Always disconnect and remove the Li-Po battery from the aircraft after each flight. Charge your Li-Po battery to about half capacity before storage. Make

sure the battery charge does not fall below 3V per cell. Failure to unplug a connected battery will result in trickle discharge.

For your first flights, set your transmitter timer or a stopwatch to 4 minutes. Adjust your timer for longer or shorter flights once you have flown the model.

**NOTICE:** Repeated flying to LVC will damage the battery.

## Transmitter and Receiver Binding

Binding is the process of programming the receiver to recognize the GUID (Globally Unique Identifier) code of a single specific transmitter. You need to 'bind' your chosen Spektrum™ DSM2/DSMX technology equipped aircraft transmitter to the receiver for proper operation.

Any full range Spektrum DSM2/DSMX transmitter can bind to the DSM2/DSMX receiver. Please visit [www.bindnfly.com](http://www.bindnfly.com) for a complete list of compatible transmitters.

### ✓ Binding Procedure

**⚠ CAUTION:** When using a Futaba transmitter with a Spektrum DSM® module, you must reverse the throttle channel and rebind. Refer to your Spektrum module manual for binding and failsafe instructions. Refer to your Futaba transmitter manual for instructions on reversing the throttle channel.

	1. Refer to your transmitter's unique instructions for binding to a receiver (location of transmitter's Bind control).
	2. Make sure the flight battery is disconnected from the aircraft.
	3. Power off your transmitter.
	4. Connect the flight battery in the aircraft. Keep the plane immobile for 5 seconds. The receiver LED will begin to flash rapidly (typically after 5 seconds).
	5. Make sure the transmitter controls are neutral and the throttle and throttle trim are in low position.
	6. Put your transmitter into bind mode. Refer to your transmitter's manual for binding button or switch instructions.
	7. After 5 to 10 seconds, the receiver status LED will turn solid, indicating that the receiver is bound to the transmitter. If the LED does not turn solid, refer to the Troubleshooting Guide at the back of the manual.

For subsequent flights, power on the transmitter for 5 seconds before connecting the flight battery.

## Alternate Flight Mode Programming

Out of the box, the AS3Xtra comes standard with 3 flight modes, shown in bold in the chart to the right.

A transmitter with a 2-position channel 5 switch will only allow the use of position 0 or position 2 flight modes.

If possible (refer to your transmitter manual) assign channel 5 in your transmitter to a 3 position switch to operate all 3 flight modes. You can modify the flight modes available using the directions below.

**NOTICE:** Fast forward flight in the Hover and Torque Roll Assist modes may cause oscillation and damage to the aircraft.



Flight Mode		Benefits
Default	<b>General Flight</b>	Heading hold on ailerons, standard AS3X on elevator and rudder.
	<b>Standard AS3X</b>	Standard AS3X on ailerons, elevator and rudder.
	<b>Hover Assistance</b>	Aggressive heading hold on ailerons, elevator and rudder.
Alternate	Knife Edge Assist	Heading hold on ailerons, elevator and rudder.
	Torque Roll Assist	Standard AS3X on ailerons, aggressive heading hold on elevator and rudder.

**IMPORTANT:** Your transmitter must be bound to the receiver before changing flight mode programming.

1. Ensure all servo reversing is set to normal in the transmitter.
2. Hold the transmitter sticks as shown, then connect the flight battery. The assigned flight mode switch does not need to be in a particular position.
3. The receiver LED will flash 3 times to confirm that the flight mode has been changed.
4. After a switch position change, fully lower the throttle, then disconnect the flight battery. The receiver stores the new flight mode for future flights.
5. Repeat this process to change other flight modes, or reset all settings to default using the chart provided.

**NOTICE:** Always launch the aircraft in General Flight or Standard AS3X® mode or damage to the aircraft may result.

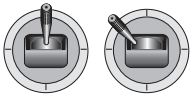
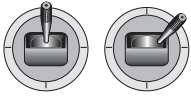
**IMPORTANT:** When the throttle is fully lowered for 1–2 seconds, the aircraft will reset to Standard AS3X mode until the throttle is raised again. This is normal. Standard AS3X mode allows you to launch the model again without a control input being held.

Default Flight Mode	Alternate Flight Mode	Ch 5 Switch Position	Mode Programming Stick Positions (Mode 2 shown)
General Flight	Standard AS3X®	0	
Standard AS3X®	Knife Edge Assist	1	
Hover Assist	Torque Roll Assist	2	
Reset all to Default Settings			

## ESC/Receiver Arming, Battery Installation and Center of Gravity

**⚠ CAUTION:** Always keep hands away from the propeller. When armed, the motor will turn the propeller in response to any throttle movement.

Arming the ESC/receiver also occurs after binding as previously described, but subsequent connection of a flight battery requires the following steps.

### AS3X

The AS3X® system will not **activate** until the throttle stick or trim is increased for the first time. Once active, the control surfaces may move rapidly and noisily on the aircraft. This is normal. AS3X technology will remain active until the battery is disconnected.

1. Apply hook and loop tape to the battery.
2. Attach the battery to the hook and loop strip on the fuselage.

### Center of Gravity (CG)

**81mm** forward from the trailing edge of the aileron at the fuselage.

3. Lower the throttle and throttle trim to the lowest settings on your transmitter. Power on your transmitter, then wait 5 seconds.
4. Connect the battery to the ESC, noting proper polarity. Keep the plane immobile and away from wind for 5 seconds to allow the AS3X system to initialize. A continuous LED indicates a successful connection.

**⚠ CAUTION:** Always disconnect the Li-Po battery from the ESC when not flying to eliminate power supplied to the motor. The ESC does not have an arming switch and will respond to any transmitter input when a signal is present.

**⚠ CAUTION:** Always disconnect the Li-Po battery from the ESC when not flying to avoid over-discharging the battery. Batteries discharged to a voltage lower than the lowest approved voltage may become damaged, resulting in loss of performance and potential fire when batteries are charged.

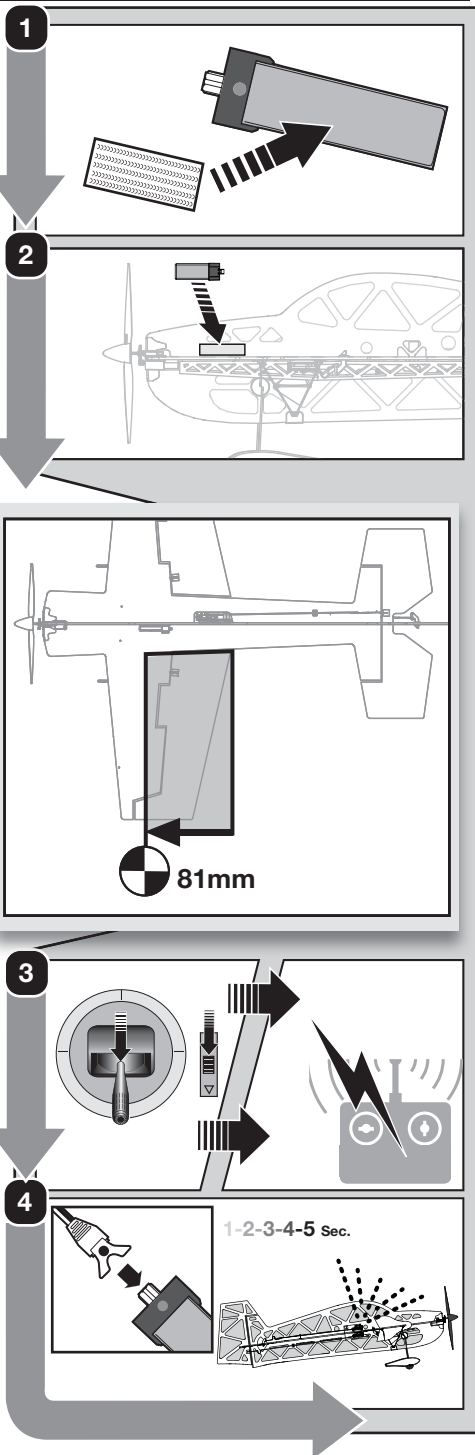

## Optional Side Force Generators (SFGs) Installation

Side Force Generators add side force in all flight attitudes, increase rudder authority and make a variety of aerobatics possible.

1. Slide the SFG slot on the wing so the lower half of the SFG is under the carbon wing supports.
2. Turn the SFG carefully so the carbon supports fit into the SFG.
3. Secure the SFGs to the wing and carbon supports using foam-safe CA (cyanoacrylate adhesive).

**NOTICE:** Install the SFGs vertically on the wing. Failure to install the SFGs at a 90° angle may result in incorrect flight performance.

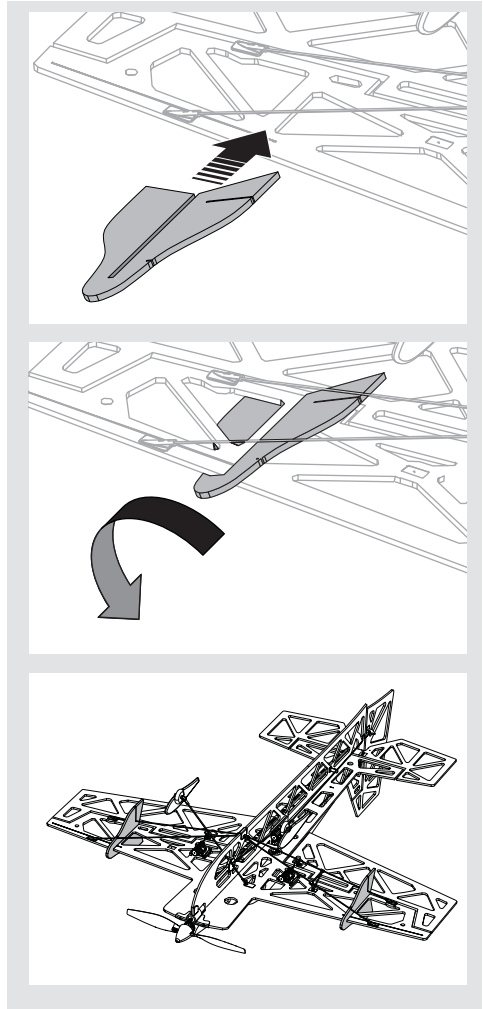

## Control Direction Test

You should bind your aircraft and transmitter before doing these tests. Move the controls on the transmitter to make sure the aircraft control surfaces move correctly and in the proper direction.

Make sure all linkages move freely.



## Control Centering

Before the first flights, or in the event of an accident, make sure the flight control surfaces are centered. Adjust the linkages mechanically if the control surfaces are not centered. Use of the transmitter sub-trims may not correctly center the aircraft control surfaces due to the mechanical limits of linear servos.

1. Make sure the control surfaces are neutral when the transmitter controls and trims are centered. The transmitter sub-trim must always be set to zero.
2. When needed, use a pair of pliers to carefully bend the metal linkage (see illustration).
3. Make the U-shape narrower to make the connector shorter. Make the U-shape wider to make the linkage longer.

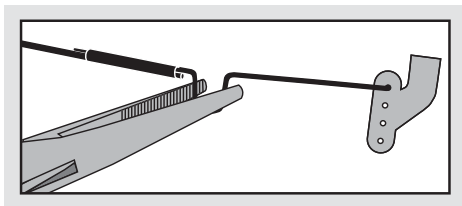

## Trimming

After adjusting transmitter trim in the air or on the ground, do not touch the control sticks for 2 seconds. This allows the receiver to learn the correct settings to optimize AS3X performance. Failure to do so could affect flight performance.

**IMPORTANT:** Only trim your aircraft in General or Standard Flight mode.

## Control Horn Settings

The illustration shows linkage positions chosen for the best aerobatic response. Linkage connections on the control horns directly affect aircraft response.

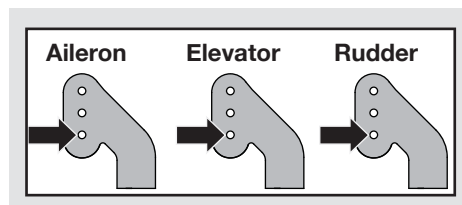

## Dual Rates

To obtain the best flight performance, we recommend using a DSM2/DSMX radio capable of Dual Rates. The suggested settings shown here are the recommended starting settings. Adjust according to the individual preferences after the initial flight.

**NOTICE: Do not set your transmitter travel adjust over 100%.** If the TRAVEL ADJUST is set over 100%, it will not result in more control movement, it will overdrive the servo and cause damage.

It is normal for linear servos to make significant noise. The noise is not an indication of a faulty servo.

	Dual Rate		
	Low	High	3D
Aileron	50%	70%	100%
Elevator	40%	70%	100%
Rudder	50%	70%	100%

**Tip:** For the first flight, fly the model in low rate.

## Flying Tips and Repairs

We recommend flying your aircraft indoors in a gymnasium, or outdoors in calm conditions. Always avoid flying near houses, trees, wires and buildings. You should also be careful to avoid flying in areas where there are many people, such as busy parks, schoolyards or soccer fields. Consult local laws and ordinances before choosing a location to fly your aircraft.

**NOTICE:** Always launch the aircraft in General Flight or Standard AS3X® mode or damage to the aircraft may result.

### Takeoff

Place the aircraft in position for takeoff (facing into the wind if flying outdoors). Set dual rates to low position and gradually increase the throttle to  $\frac{3}{4}$  to full and steer with the rudder. Pull back gently on the elevator and climb to check trim. Once the trim is adjusted, begin exploring the flight envelope of the aircraft.

Failure to lower the throttle stick and trim to the lowest possible positions during a crash could result in damage to the ESC in the receiver unit, which may require replacement.

**NOTICE:** Crash damage is not covered under the warranty.

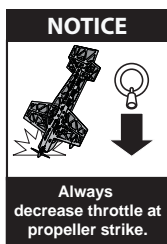

### Repairs

Repair the aircraft using foam-compatible CA (cyanoacrylate adhesive) or clear tape. **Only use foam-compatible CA**, as other types of glue can damage the foam. When parts are not repairable, see the Replacement Parts List for ordering by item number.

For a listing of all replacement and optional parts, refer to the list at the end of this manual.

**NOTICE:** Use of foam-compatible CA accelerant on your aircraft can damage the color printing on the film. DO NOT handle the aircraft until the accelerant fully dries.

**IMPORTANT:** The film on the aircraft may show wrinkles. Wrinkles vary with the passage of time and do not change the aircraft's flight performance.

**NOTICE:** When you are finished flying, never leave the aircraft in direct sunlight or in a hot, enclosed area such as a car. Doing so can damage the aircraft

## Post Flight Checklist

✓	
	1. Disconnect the flight battery from the ESC (Required for safety and battery life).
	2. Power OFF the transmitter.
	3. Remove the flight battery from the aircraft.
	4. Recharge the flight battery.

✓	
	5. Store the flight battery apart from the aircraft and monitor the battery charge.
	6. Make note of the flight conditions and flight plan results, planning for future flights.

# Power Components Service

## Disassembly

**⚠ CAUTION:** DO NOT handle the propeller while the flight battery is connected to the ESC. Personal injury could result.

1. Disconnect the battery from the ESC/receiver.
2. Hold the prop shaft using needle-nose pliers or hemostats.
3. Turn the propeller counterclockwise (facing the front of the model) to remove. Turn the propeller clockwise to install.
4. Carefully remove the damaged spinner and glue from the propeller.
5. Hold the nut on the end of the prop shaft using needle-nose pliers or hemostats.
6. Turn the gear on the shaft clockwise (facing the front of the model) to remove the nut.
7. Gently pull the shaft (A) from the gearbox (B). Make sure the washer (C) and two bushings (D) are not lost.
8. Disconnect the motor from the ESC/receiver.
9. Gently push the motor out of the gearbox and remove the motor from the fuselage.

**NOTICE:** DO NOT remove the gearbox from the aircraft. Damage to the aircraft will result.

## Assembly

Assemble the aircraft using the instructions above in reverse order.

- Correctly align the prop shaft gear with the pinion gear on the motor.
- Connect the motor to the ESC/receiver so that the powered motor turns the propeller counterclockwise (facing the front of the model).
- Make sure the propeller size numbers (130 x 70) face away from the motor (see illustration).
- Attach the spinner to the propeller using foam-compatible CA (Cyanoacrylate adhesive).

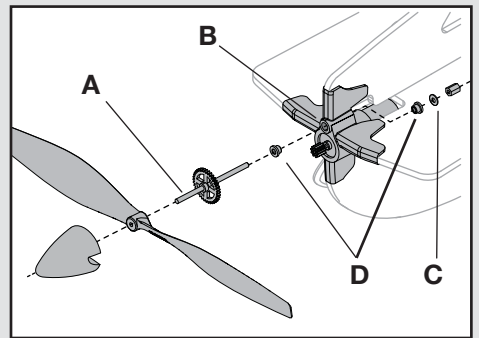
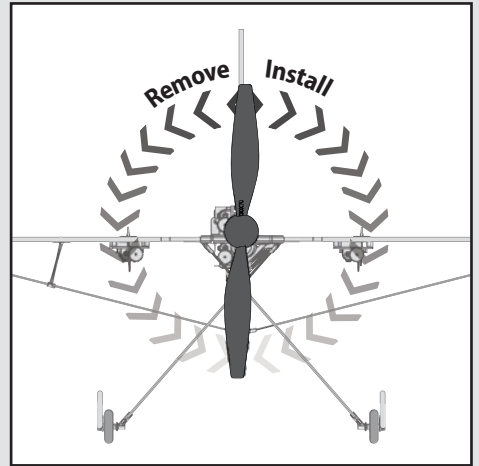

# Troubleshooting Guide

<b>AS3X</b>		
<b>Problem</b>	<b>Possible Cause</b>	<b>Solution</b>
Control surfaces not at neutral position when transmitter controls are at neutral	Control surfaces may not have been mechanically centered from factory	Center control surfaces mechanically by adjusting the U-bends on control linkages
ESC/receiver does not arm when the battery is connected	Aircraft was not kept immobile for 5 seconds	Disconnect and reconnect the flight battery while keeping the aircraft still for 5 seconds with throttle stick in lowest position.
Aircraft oscillates in fast forward flight	Incorrect flight mode	Decrease throttle, then change to General Flight or a Standard AS3X flight mode
Controls oscillate in flight, (model rapidly jumps or moves)	Propeller is unbalanced, causing excessive vibration	Remove propeller and rebalance or replace it if damaged

<b>Problem</b>	<b>Possible Cause</b>	<b>Solution</b>
Aircraft will not respond to throttle but responds to other controls	Throttle stick and/or throttle trim too high	Reset controls with throttle stick and throttle trim at lowest setting
	Throttle channel is reversed	Reverse throttle channel on transmitter
	Motor disconnected from receiver	Open fuselage and make sure motor is connected to the receiver
Extra propeller noise or extra vibration	Damaged propeller, spinner or motor	Replace damaged parts
	Prop screw is too loose	Tighten the prop screw
	Prop is out of balance	Remove and balance propeller, or replace with a balanced propeller.
Reduced flight time or aircraft underpowered	Flight battery charge is low	Completely recharge flight battery
	Propeller installed backwards	Install propeller with numbers facing forward
	Flight battery damaged	Replace flight battery and follow flight battery instructions
	Flight conditions may be too cold	Make sure battery is warm before use
	Battery capacity too low for flight conditions	Replace battery or use a larger capacity battery
LED on receiver flashes and aircraft will not bind to transmitter (during binding)	Transmitter too near aircraft during binding process	Power off transmitter, move transmitter a larger distance from aircraft, disconnect and reconnect flight battery to aircraft and follow binding instructions
	Bind switch or button not held long enough during bind process	Power off transmitter and repeat bind process. Hold transmitter bind button or switch until receiver is bound
	Aircraft or transmitter is too close to large metal object, wireless source or another transmitter	Move aircraft and transmitter to another location and attempt binding again

## Troubleshooting Guide (Continued)

Problem	Possible Cause	Solution
LED on receiver flashes rapidly and aircraft will not respond to transmitter (after binding)	Less than a 5-second wait between first powering on transmitter and connecting flight battery to aircraft	Leaving transmitter on, disconnect and reconnect flight battery to aircraft
	Aircraft bound to different model memory (ModelMatch™ radios only)	Select correct model memory on transmitter and disconnect and reconnect flight battery to aircraft
	Flight battery/transmitter battery charge is too low	Replace/recharge batteries
	Transmitter may have been bound to a different model (or with a different DSM Protocol)	Select the right transmitter or bind to the new one
	Aircraft or transmitter is too close to large metal object, wireless source or another transmitter	Move aircraft and transmitter to another location and attempt linking again
Control surface does not move	Control surface, control horn, linkage or servo damage	Replace or repair damaged parts and adjust controls
	Wire damaged or connections loose	Do a check of wires and connections, connect or replace as needed
	Flight battery charge is low	Fully recharge flight battery
	Control linkage does not move freely	Make sure control linkage moves freely
Controls reversed	Transmitter settings reversed	Adjust controls on transmitter appropriately
Motor loses power	Damage to motor or power components	Do a check of motor and power components for damage (replace as needed)
Motor power quickly decreases and increases then motor loses power	Battery power is down to the point of receiver/ESC Low Voltage Cutoff (LVC)	Recharge flight battery or replace battery that is no longer performing
Servo locks or freezes at full travel	Travel adjust value is set above 100%, overdriving the servo	Set Travel adjust to 100% or less and/or set sub-trims to Zero and adjust linkages mechanically

## Limited Warranty

### What this Warranty Covers

Horizon Hobby, Inc. ("Horizon") warrants to the original purchaser that the product purchased (the "Product") will be free from defects in materials and workmanship at the date of purchase.

### What is Not Covered

This warranty is not transferable and does not cover (i) cosmetic damage, (ii) damage due to acts of God, accident, misuse, abuse, negligence, commercial use, or due to improper use, installation, operation or maintenance, (iii) modification of or to any part of the Product, (iv) attempted service by anyone other than a Horizon Hobby authorized service center, (v) Product

not purchased from an authorized Horizon dealer, or (vi) Product not compliant with applicable technical regulations.

OTHER THAN THE EXPRESS WARRANTY ABOVE, HORIZON MAKES NO OTHER WARRANTY OR REPRESENTATION, AND HEREBY DISCLAIMS ANY AND ALL IMPLIED WARRANTIES, INCLUDING, WITHOUT LIMITATION, THE IMPLIED WARRANTIES OF NON-INFRINGEMENT, MERCHANTABILITY AND FITNESS FOR A PARTICULAR PURPOSE. THE PURCHASER ACKNOWLEDGES THAT THEY ALONE HAVE DETERMINED THAT THE PRODUCT WILL SUITABLY MEET THE REQUIREMENTS OF THE PURCHASER'S INTENDED USE.

## Purchaser's Remedy

Horizon's sole obligation and purchaser's sole and exclusive remedy shall be that Horizon will, at its option, either (i) service, or (ii) replace, any Product determined by Horizon to be defective. Horizon reserves the right to inspect any and all Product(s) involved in a warranty claim. Service or replacement decisions are at the sole discretion of Horizon. Proof of purchase is required for all warranty claims. **SERVICE OR REPLACEMENT AS PROVIDED UNDER THIS WARRANTY IS THE PURCHASER'S SOLE AND EXCLUSIVE REMEDY.**

## Limitation of Liability

HORIZON SHALL NOT BE LIABLE FOR SPECIAL, INDIRECT, INCIDENTAL OR CONSEQUENTIAL DAMAGES, LOSS OF PROFITS OR PRODUCTION OR COMMERCIAL LOSS IN ANY WAY, REGARDLESS OF WHETHER SUCH CLAIM IS BASED IN CONTRACT, WARRANTY, TORT, NEGLIGENCE, STRICT LIABILITY OR ANY OTHER THEORY OF LIABILITY, EVEN IF HORIZON HAS BEEN ADVISED OF THE POSSIBILITY OF SUCH DAMAGES. Further, in no event shall the liability of Horizon exceed the individual price of the Product on which liability is asserted. As Horizon has no control over use, setup, final assembly, modification or misuse, no liability shall be assumed nor accepted for any resulting damage or injury. By the act of use, setup or assembly, the user accepts all resulting liability. If you as the purchaser or user are not prepared to accept the liability associated with the use of the Product, purchaser is advised to return the Product immediately in new and unused condition to the place of purchase.

## Law

These terms are governed by Illinois law (without regard to conflict of law principals). This warranty gives you specific legal rights, and you may also have other rights which vary from state to state. Horizon reserves the right to change or modify this warranty at any time without notice.

## WARRANTY SERVICES

### Questions, Assistance, and Services

Your local hobby store and/or place of purchase cannot provide warranty support or service. Once assembly, setup or use of the Product has been started, you must contact your local distributor or Horizon directly. This will enable Horizon to better answer your questions and service you in the event that you may need any assistance. For questions or assistance, please visit our website at [www.horizonhobby.com](http://www.horizonhobby.com), submit a Product Support Inquiry, or call the toll free telephone number referenced in the Warranty and Service Contact Information section to speak with a Product Support representative.

### Inspection or Services

If this Product needs to be inspected or serviced and is compliant in the country you live and use the Product in, please use the Horizon Online Service Request submission process found on our website or call Horizon to obtain a Return Merchandise Authorization (RMA) number. Pack the Product securely using a shipping carton. Please note that original boxes may be included, but are not designed to withstand the rigors of shipping without additional protection. Ship via a carrier that provides tracking and insurance for lost or damaged parcels, as Horizon is not responsible for merchandise until it arrives and is accepted at our facility. An Online Service Request is available at [http://www.horizonhobby.com/content/\\_service-center\\_render-service-center](http://www.horizonhobby.com/content/_service-center_render-service-center). If you do not have internet access, please contact Horizon Product Support

to obtain a RMA number along with instructions for submitting your product for service. When calling Horizon, you will be asked to provide your complete name, street address, email address and phone number where you can be reached during business hours. When sending product into Horizon, please include your RMA number, a list of the included items, and a brief summary of the problem. A copy of your original sales receipt must be included for warranty consideration. Be sure your name, address, and RMA number are clearly written on the outside of the shipping carton.

**NOTICE: Do not ship LiPo batteries to Horizon. If you have any issue with a LiPo battery, please contact the appropriate Horizon Product Support office.**

## Warranty Requirements

**For Warranty consideration, you must include your original sales receipt verifying the proof-of-purchase date.** Provided warranty conditions have been met, your Product will be serviced or replaced free of charge. Service or replacement decisions are at the sole discretion of Horizon.

## Non-Warranty Service

**Should your service not be covered by warranty, service will be completed and payment will be required without notification or estimate of the expense unless the expense exceeds 50% of the retail purchase cost.** By submitting the item for service you are agreeing to payment of the service without notification. Service estimates are available upon request. You must include this request with your item submitted for service. Non-warranty service estimates will be billed a minimum of ½ hour of labor. In addition you will be billed for return freight. Horizon accepts money orders and cashier's checks, as well as Visa, MasterCard, American Express, and Discover cards. By submitting any item to Horizon for service, you are agreeing to Horizon's Terms and Conditions found on our website [http://www.horizonhobby.com/content/\\_service-center\\_render-service-center](http://www.horizonhobby.com/content/_service-center_render-service-center).

**ATTENTION: Horizon service is limited to Product compliant in the country of use and ownership. If received, a non-compliant Product will not be serviced. Further, the sender will be responsible for arranging return shipment of the un-serviced Product, through a carrier of the sender's choice and at the sender's expense. Horizon will hold non-compliant Product for a period of 60 days from notification, after which it will be discarded.**

## Warranty and Service Information

Country of Purchase	Horizon Hobby	Phone Number/Email Address	Address
United States of America	Horizon Service Center (Repairs and Repair Requests)	servicecenter.horizonhobby.com/RequestForm/	4105 Fieldstone Rd Champaign, Illinois, 61822 USA
	Horizon Product Support (Product Technical Assistance)	www.quickbase.com/db/bghj7ey8c?a=GenNewRecord 888-959-2305	
	Sales	sales@horizonhobby.com 888-959-2305	
United Kingdom	Service/Parts/Sales: Horizon Hobby Limited	sales@horizonhobby.co.uk +44 (0) 1279 641 097	Units 1-4 , Ployters Rd, Staple Tye Harlow, Essex, CM18 7NS, United Kingdom
Germany	Horizon Technischer Service Sales: Horizon Hobby GmbH	service@horizonhobby.de +49 (0) 4121 2655 100	Christian-Junge-Straße 1 25337 Elmshorn, Germany
France	Service/Parts/Sales: Horizon Hobby SAS	infofrance@horizonhobby.com +33 (0) 1 60 18 34 90	11 Rue Georges Charpak 77127 Lieusaint, France
China	Service/Parts/Sales: Horizon Hobby – China	info@horizonhobby.com.cn +86 (021) 5180 9868	Room 506, No. 97 Changshou Rd. Shanghai, China 200060

## Compliance Information for the European Union

### Declaration of Conformity

(in accordance with ISO/IEC 17050-1)  
No. HH2013091304



Product(s):  
Item Number(s):  
Equipment class:

EFL AS3Xtra BNF Basic  
EFLU5150  
1

The object of declaration described above is in conformity with the requirements of the specifications listed below, following the provisions of the European R&TTE Directive 1999/5/EC and EMC Directive 2004/108/EC:

**EN 301 489-1 V1.9.2: 2012**  
**EN 301 489-17 V2.1.1: 2009**

**EN55022:2010 + AC:2011**  
**EN55024:2010**

Signed for and on behalf of:  
Horizon Hobby, Inc.  
Champaign, IL USA  
Sep 13, 2013

Robert Peak  
Chief Financial Officer  
Horizon Hobby, Inc.

## Instructions for disposal of WEEE by users in the European Union



This product must not be disposed of with other waste. Instead, it is the user's responsibility to dispose of their waste equipment by handing it over to a designated collections point for the recycling of waste electrical and electronic equipment. The separate collection and recycling of your waste equipment at the time of disposal will help to conserve natural resources and ensure that it is recycled in a manner that protects human health and the environment. For more information about where you can drop off your waste equipment for recycling, please contact your local city office, your household waste disposal service or where you purchased the product.

## Replacement Parts – Ersatzteile – – Pièces de rechange – Recapiti per i Ricambi –

Part # • Nummer Numéro • Codice	Description	Beschreibung	Description	Descrizione
EFLU5152	Ultra Micro Brushed Motor 8.5mm x 23mm	E-flite Ultra Micro Brushed Motor 8.5mm x 23mm	Ultra micro moteur coreless 8.5mmx23mm	Motore a spazzole ultra micro 8.5mm x 23mm
EFLU5153	Gearbox with Propshaft: UMX AS3Xtra	E-flite UMX AS3Xtra: Propellerwelle m. Getriebe	Réducteur avec arbre d'hélice	Riduttore con albero elica: UMX AS3Xtra
EFLU5170	Replacement Airframe: UMX AS3Xtra	E-flite UMX AS3Xtra: Rumpf o. Einbauten	Structure de remplacement	Struttura velivolo di ricambio: UMX AS3Xtra
EFLU5156	Hardware/Pushrod Set: UMX AS3Xtra	E-flite UMX AS3Xtra: Kleinteile / Anlenkungen	Set de tringleries et d'accessoires	Set comandi e viteria: UMX AS3Xtra
EFL9051	Propeller with Spinner (2): 130mm x 70mm	E-flite Ultra-Micro 4-Site Luftschraube und Spinner	Hélice 130x70mm avec cônes(2)	Elica con ogiva (2): 130mm x 70mm
EFL9054	Prop Shaft With Gear (2): UMX 4-Site/Extra 300 3D	E-flite Ultra-Micro 4-Site Luftschraubenwelle mit Getriebe	Arbre d'hélice avec couronne (2)	Albero elica con ingranaggio(2): UMX 4-Site/Extra 300 3D
SPMSA2030L	2.3-Gram Performance Linear Long Throw Servo	2,3 Gramm Hochleistungs - Linear Servo mit langem Ruderweg	Servo 2.3g linéaire longue course performant	Ottimo servo lineare a corsa lunga da 2,3 Grammi
PKZ3052	Battery Connector with Wire	Parkzone Ladekabel Micro Lipo Akkus	Prise de batterie avec câbles	Connettore batteria con filo
EFLU5164	DSM2/DSMX UM AS3X Receiver/ESC, UMX AS3Xtra	E-flite UMX AS3Xtra: DSM2/DSMX UM AS3X Empfänger / ESC	Module RX/Vario/AS3X	Ricevitore/ESC DSM2/ DSMX UM AS3X , UMX AS3Xtra



**– Optional Parts and Accessories –**  
**– Optionale Bauteile und Zubehörteile –**  
**– Pièces optionnelles et accessoires –**  
**– Parti opzionali e accessori –**

Part # • Nummer Numéro • Codice	Description	Beschreibung	Description	Descrizione
PKZ1039	Hook and Loop Set (5): Ultra Micros	Parkzone: Klettband Set Ultra Micros	Ultras Micros - Bande auto-agrippante (5)	Set fascette a strappo (5): Ultra Micro
EFLB1501S25	1S 3.7V 150mAh 25C Li-Po Battery	1S 3.7V 150mAh 25C Li-Po Akku	Batterie Li-Po 3.7V 1S 150mA 25C	1S 3.7V 150mAh 25C Li-Po Batteria
EFLB1501S45	1S 3.7V 150mAh 45C Li-Po Battery	1S 3.7V 150mAh 45C Li-Po Akku	Batterie Li-Po 3.7V 1S 150mA 45C	1S 3.7V 150mAh 45C Li-Po Batteria
EFLC1004	Celectra 4-Port 1S 3.7V 0.3A DC Li-Po Charger	E-flite 4 Port Ladegerät 1S 3,7V 0,3A	Chargeur Li-Po CC 0,3 A 3, 7V 1S 4 ports Celectra	Caricabatterie Li-Po 1S da 3,7V 0,3 A CC, a 4 porte, Celectra
EFLC1005/UK/AU/EU	AC to 6V DC, 1.5 Amp Power Supply (Based upon your sales Region)	Netzteil 6V 1,5 A (Basierend nach Vertriebsregion)	Alimentation CA vers 6V CC, 1,5 A (En fonction de votre région)	Alimentatore CA - 6V CC da 1,5 A (in base al Paese di vendita)
	DX5e DSMX 5-Channel Transmitter	DX5e DSMX 5-Kanal Sender	Emetteur DX5e DSMX 5 voies	DX5e DSMX Trasmettitore 5 canali
	DX6i DSMX 6-Channel Transmitter	DX6i DSMX 6-Kanal Sender	Emetteur DX6i DSMX 6 voies	DX6i DSMX Trasmettitore 6 canali
	DX7s DSMX 7-Channel Transmitter	Spektrum DX7s 7 Kanal Sender	Emetteur DX7s DSMX 7 voies	DX7s DSMX Trasmettitore 7 canali
	DX8 DSMX Transmitter	Spektrum DX8 nur Sender	Emetteur DX8 DSMX 8 voies	DX8 DSMX Solo trasmettitore
	DX9 DSMX Transmitter	Spektrum DX9 nur Sender	Emetteur DX9 DSMX 8 voies	DX9 DSMX Solo trasmettitore
	DX18/DX18QQ Transmitter	Spektrum DX18/ DX18QQ nur Sender	Emetteur DX18/ DX18QQ DSMX 8 voies	DX18 /DX18QQ DSMX Solo trasmettitore

© 2013 Horizon Hobby, Inc.

E-flite, AS3X, Blade, Celectra, UMX, DSM, DSM2, DSMX, ModelMatch, Bind-N-Fly, the BNF logo and the Horizon Hobby logo are trademarks or registered trademarks of Horizon Hobby, Inc.

The Spektrum trademark is used with permission of Bachmann Industries, Inc.

Futaba is a registered trademark of Futaba Denshi Kogyo Kabushiki Kaisha Corporation of Japan.

US 7,898,130. US D578,146. PRC ZL 200720069025. PRC ZL 2007001249.  
Other patents pending.

[www.e-fliterc.com](http://www.e-fliterc.com)

